

NOTICE: TO ALL OWNERS OF OCTAVE SYNTHESIZERS

To help make Octave Synthesizers better suit your personal needs, certain custom modifications are now available subject to the following terms:

- 1) All modifications must be performed by the factory only.
- 2) Shipping charges both to and from the factory must be prepaid by the customer.
- 3) A certified check or money order must accompany the unit or be mailed in advance.
- 4) Customer must contact the factory in writing for a RETURN AUTHORIZATION NUMBER prior to shipping the unit. Units with no return authorization number will be refused by the factory.
- 5) Modifications are guaranteed for 1 year parts and 90 days labor and are subject to the standard terms of the OCTAVE warrantee as supplied with the unit.
- 6) The factory reserves the right to select the orientation of panel control additions dependent upon space variations.
- 7) Along with the modification performed, the unit will be recalibrated and given a general check. No repairs will be performed unless the customer is notified.

A portion of the cost of a modification is due to the fact that the instrument has to be dismantled and reconstructed in order to gain access to the modified areas. Because of this, several modifications performed on the same unit at the same time will be less expensive than those modifications done separately.

In view of this, the following discounts apply to multiple modifications performed on the same unit at the same time:

First modification: Price as listed
Each add'l modification: Less \$10.00 per modification

Please inquire in writing about any modifications not listed that would better suit your needs.

<u>MOD #</u>	<u>TITLE</u>	<u>AVAILABILITY</u>	<u>INCLUDES</u>	<u>PRICE</u>
M-01	HP/LP VCF	SRM, Kitten	panel sw.	\$40.00
M-02	12/24dB VCF Rolloff	All models	panel sw.	\$40.00
M-03	Manual HPF	All models	panel pot	\$45.00
M-04	LFO Square Wave Offset	All models	panel sw.	\$40.00
M-05	LFO Monitor	A-1000 series	panel lamp	\$40.00
M-06	LFO Delay	A-1000 series	panel pot	\$80.00
M-07	LFO Sine Amplitude Control	All models	panel pot jack, pedal	\$85.00
M-08	Pitch Bend Interval Control	All models	panel pot	\$40.00
M-09	Center-lock Pitch Bend	A-1000 series		\$30.00
M-10	Interface Pedal input	All models	jack, pedal	\$75.00
M-11	Ganged Modulation Atten.	A-1000, SRM	4 panel sw.	\$50.00
M-12	2-Note Memory	A-1000	new keyboard	\$225.00
M-13	VCA Pedal Input	All models	jack, pedal	\$80.00
M-14	VCO2 Pedal Input	A-1000, SRM	jack, pedal	\$75.00
M-15	VCO1 Pedal Input	A-1000 series	jack, pedal	\$75.00
M-16	White/Pink noise	All models	panel switch	\$40.00
M-17	Keyboard Trigger of S&H	All models	panel switch	\$40.00
M-18	Glide on Auto S&H	All models	panel pot	\$40.00
M-19	Ring Modulator	A-1000, SRM	3 pots, 2 jacks	\$240.00
M-20	VCO1, VCO2, Noise Series Outputs	A-1000, SRM	3 jacks	\$50.00
		Kitten	2 jacks	\$45.00
M-21	VCF Bypass Switches	A-1000, SRM	3 panel sw.	\$50.00
M-22	Input/Output Patching System	A-1000, SRM	11 jacks	\$150.00
M-23	Set of SRM panel knobs	A-1000	12 rotary 20 slider knobs	\$20.00

PACKAGE PRICES:

P-01 UPGRADE OF A-1000SERIES TO SRM STATUS

price \$370.00

This package is recommended for those wishing to upgrade the performance of their A-1000 series CAT to the SRM level.

Package includes:	M-05	LFO monitor	\$40.00	
	M-06	LFO Delay	80.00	
	M-09	Center locked pitch bend	30.00	
	M-12	2-Note Memory	225.00	
	M-15	VCO1 pedal input	75.00	(includes pedal)
	M-23	SRM panel knobs	20.00	
		total	<u>\$470.00</u>	
		package	370.00	

P-02 ELECTRONIC MUSIC STUDIO PACKAGE

price \$650.00

This package upgrades an SRM so that it can be used for electronic music studio experimentation since it allows the internal devices to interact with external systems and increases the versatility of the existing modules.

package includes:	M-01	HP/LP VCF	\$40.00	
	M-02	12/24dB VCF	40.00	
	M-04	LFO square offset	40.00	
	M-10	Interface pedal	75.00	(includes pedal)
	M-13	VCA pedal input	80.00	(includes pedal)
	M-17	Keyboard trigger on S+H	40.00	
	M-18	Glide on auto S+H	40.00	
	M-19	Ring Modulator	240.00	
	M-21	VCF bypass sw's	50.00	
	M-22	Input/Output patch system	<u>150.00</u>	
		total	795.00	
		package	650.00	

P-03 PERFORMANCE PACKAGE

price \$315.00

These modifications are packaged to significantly increase the performance versatility of the SRM.

package includes:	M-01	HP/LP VCF	\$40.00	
	M-04	LFO square offs.	40.00	
	M-07	LFO sine ampl.	85.00	(includes pedal)
	M-08	Bend interval	40.00	
	M-10	Interface pedal	75.00	(includes pedal)
	M-11	Ganged mod. atten.	50.00	
	M-13	VCA pedal	80.00	(includes pedal)
		total	<u>410.00</u>	
		package	315.00	

M-01 HIGH PASS/LOW PASS VCF SELECTOR SWITCH:

A miniature toggle switch is added to the VCF module. In one position, the VCF becomes a voltage controlled low-pass filter, as it normally is, and attenuates all frequencies above F_c . In the other position, the VCF becomes a voltage controlled high-pass filter and attenuates all frequencies below F_c .

M-02 12/24 dB/octave FILTER SLOPE

A miniature toggle switch is added to the VCF module. In one position, the VCF rolloff is 24dB/octave, as it normally is, and in the other position the rolloff becomes 12dB/octave.

M-03 MANUAL HIGH PASS FILTER

A rotary potentiometer is added to the front panel. This control adjusts the cutoff of a passive, manually set (not voltage controlled), highpass filter. The cutoff range is approximately 20Hz to 10KHz with a rolloff of -6dB/octave. The filter is placed inbetween the VCF and VCA modules.

M-04 LFO SQUARE WAVE OFFSET SWITCH

A miniature toggle switch is added to the panel. In one position, the LFO square wave alternates between ground and a positive voltage, while in the other position, the square wave alternates between balanced plus and minus voltages. This allows LFO square wave modulations above and below a reference or only above the reference.

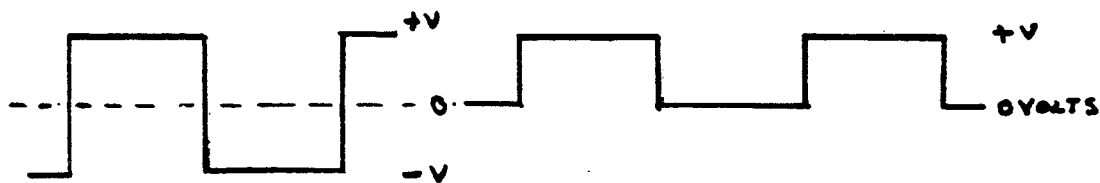

Square wave without offset

Square wave with offset

M-05 LFO MONITOR LAMP

An LED monitor lamp for the LFO frequency (similar to that on the SRM and kitten synthesizers) is added to the A-1000 series CAT synthesizers.

M-06 LFO DELAY

A rotary potentiometer is added to the front panel of the A-1000 series CAT synthesizer to control the delay time of the LFO sine wave. This delay is trigger sensitive and is continuously variable from 0 to 5 seconds. The resulting effect is similar to that of the SRM and Kitten LFO delay.

M-07 LFO SINE AMPLITUDE CONTROL (includes foot pedal)

A rotary potentiometer is added to the panel near the pitch bend slider. Also, a jack is added to the rear of the unit. When the foot pedal supplied is plugged into this jack, the LFO sine amplitude can be varied from zero to full with the pedal; the panel pot controls the pedal sensitivity.

When the pedal is not used, the panel pot determines the LFO sine amplitude.

This modification also allows external voltage control of the LFO sine wave amplitude. The tip of the pedal cable is the control voltage input. Thus, a mono cable plugged into this jack will allow external voltage sources to control the LFO sine amplitude.

Note that this modification turns the LFO triangle wave on A-1000 series CATs into a sine wave.

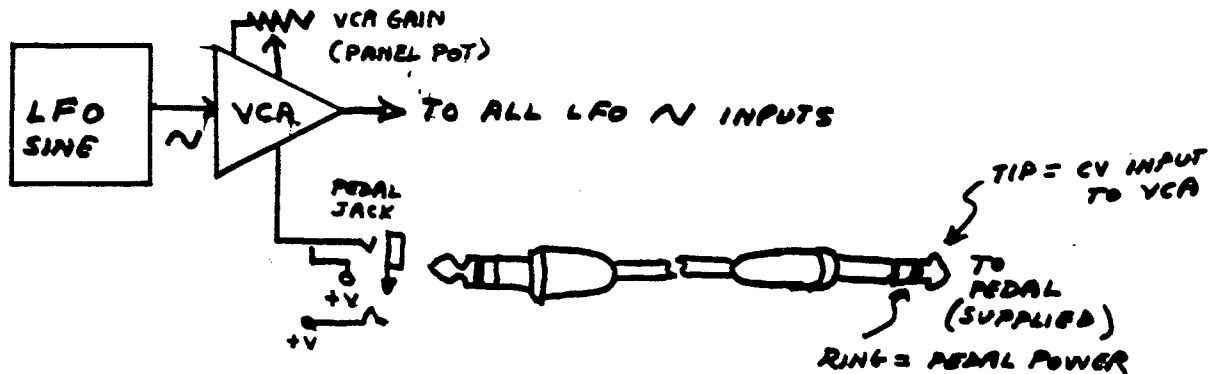

The LFO sine wave can be controlled by the panel pot, foot pedal, or by an external modulation source

M-08 PITCH BEND INTERVAL CONTROL

A rotary potentiometer is added to the front panel near the pitch bend slider. When fully counter clockwise, the ends of the pitch bend slider will shift the pitch of the unit by about 1 semitone. When the interval control is fully clockwise, the ends of the pitch bender are about 2 octaves up and down. Thus, the interval control allows variations in pitch bend sensitivity from about one semitone to about plus and minus two octaves.

M-09 CENTER LOCKING PITCH BEND SLIDER

The pitch bend slider on the A-1000 series CAT is replaced with a center locking pitch bend as on the SRM and kitten.

M-10 INTERFACE PEDAL INPUT (includes foot pedal)

A stereo jack is added to the rear of the instrument. The tip of this jack provides a 1 volt per octave input to the interface circuitry on the synthesizer. A voltage applied to this jack will shift the pitch of the entire unit in the same way as the pitch bender shifts the pitch of the entire unit.

When the pedal supplied is inserted into this jack, the pitch of the unit can be bent upwards with it. The range of the pitch bend is controlled by the sensitivity control on the pedal.

M-11 GANGED MODULATION ATTENUATORS

A miniature toggle switch is added below each of the two VCO2 modulation attenuators and the two VCF modulation attenuators. These switches cause the attenuators above them to become slaves to the VCO1 modulation attenuators. When the switch is on, the attenuator above it is disconnected from its modulation selector switch and is instead connected to the wiper of the respective VCO1 modulation attenuator.

This is useful for controlling the modulation depth of VCO 1, VCO 2 and the VCF with only the VCO 1 modulation depth controls. The figure should make this function obvious.

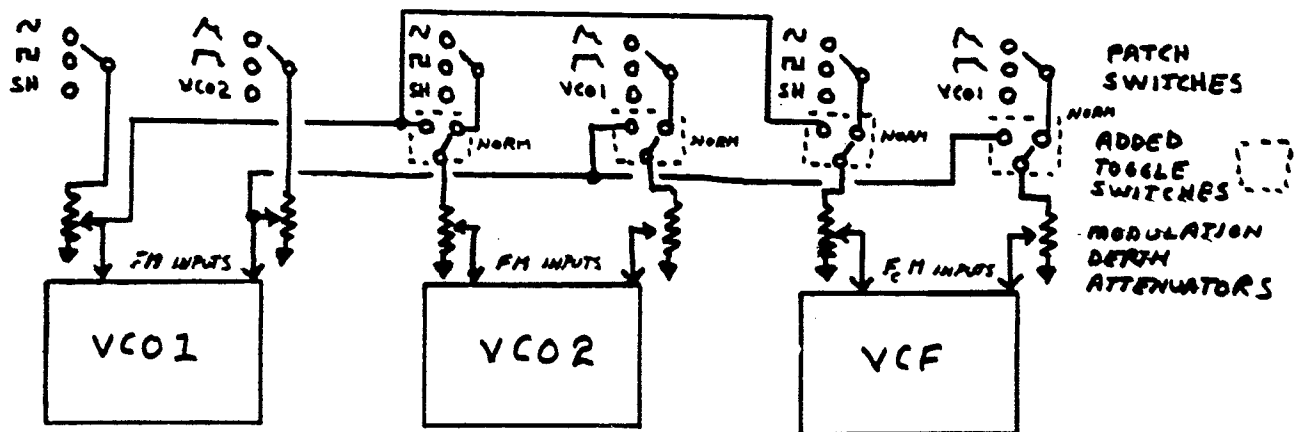

The added switches allow the VCO2 and VCF modulation depths to be governed by the VCO1 modulation depth settings so that all three modules can be varied with one or two rotary knobs.

M-12 2-NOTE MEMORY

The CAT series A-1000 memory system is upgraded to that of the SRM by adding a memory to the second note. The keyboard and internal memory circuitry are replaced (factory retains old keyboard) with the new SRM keyboard and circuitry. The external appearance of the unit is not altered.

The second memory allows the CAT second voice to be memorized after releasing the key so that both oscillators maintain the interval that was played before the keys were released.

M-13 VCA CONTROL VOLTAGE INPUT (includes pedal)

A stereo jack is added to the back of the unit to allow access to the VCA control voltage input. This jack can be used to control the volume with a footpedal (included) or to allow an external device with a 0 to +10V range to modulate the VCA.

The tip of the jack is connected to the control voltage input of the VCA and the ring of the jack is connected to the modulation select switch of the VCA. If the pedal is inserted, the modulation depth of the VCA is controlled by the pedal setting. The VCA volume control serves as a pedal sensitivity control.

If a $\frac{1}{4}$ " mono cable is inserted into the jack, the modulation select switch is disconnected and the tip of the cable provides access to the control voltage input of the VCA. Allowable control voltage range is from 0 to +10V.

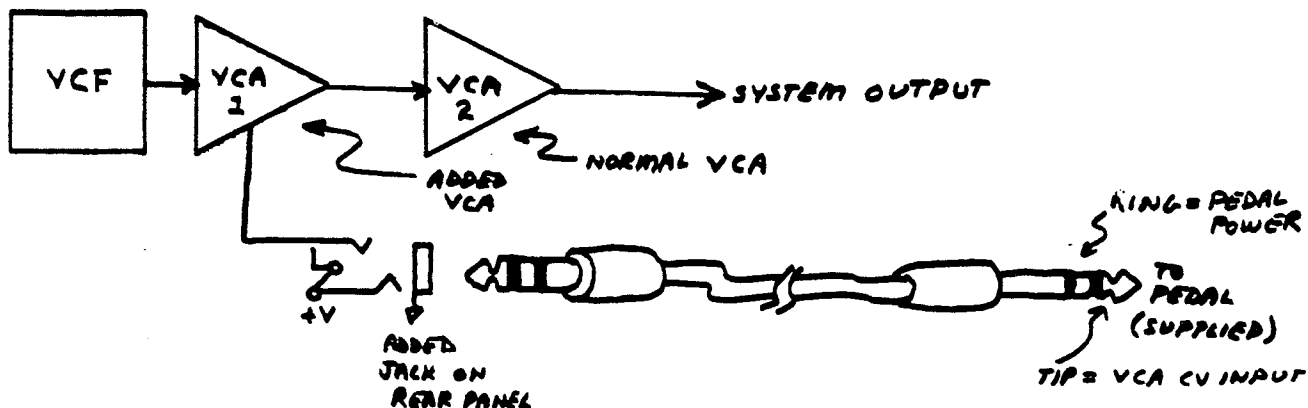

An extra VCA allows pedal control and external source control of the entire instrument's volume level

M-14 VCO2 SWEEP PEDAL INPUT (includes pedal)

A stereo jack is added to the rear of the unit to allow pedal sweeping of the VCO2 frequency similar to that of the VCO1 pedal input in the SRM and KITTEN. The tip of this jack is connected to the VCO2 control voltage input and provides a 1 volt/octave control voltage input to VCO2. A pedal is supplied with this modification.

M-15 VCO1 SWEEP PEDAL INPUT (includes pedal)

Same as VCO2 modification M-14 except for VCO1. This allows A-1000 series CATS to be upgraded to the SRM level. Pedal supplied.

M-16 WHITE/PINK NOISE SWITCH

A miniature toggle switch is added to the noise module to provide selection between white and pink noise.

M-17 KEYBOARD TRIGGERING OF AUTO S&H

A miniature toggle switch is mounted near the S&H switch. In one position, the S&H is triggered by the LFO, as it normally is. In the other position, the keyboard trigger controls the S&H and a new sample is taken on every keyboard trigger.

M-18 GLIDE CONTROL ON AUTO S&H

A rotary potentiometer is added to the panel to control the glide between sample steps. This allows gliding between notes when modulating the VCO'S with the S&H output.

M-19 RING MODULATOR

A 4-quadrant multiplier is added to the internal circuitry of the synthesizer to provide true ring modulation. One of the ring modulator inputs is connected to the VCO1 mixer output and the other input is connected to the VCO2 mixer output, thus allowing ring modulation between any of the mixed waveshapes of the 2 VCO'S. The ring modulator inputs are also connected to $\frac{1}{4}$ " mono jacks mounted on the rear of the unit. When a cable is inserted into either jack, the respective VCO is disconnected and replaced with the outside signal source. This allows either VCO to modulate an outside source. Each input is provided with a rotary attenuator. The output of the ring modulator is connected to the VCF through a rotary volume control to allow mixing of the ring modulation effects with the standard synthesizer sounds.

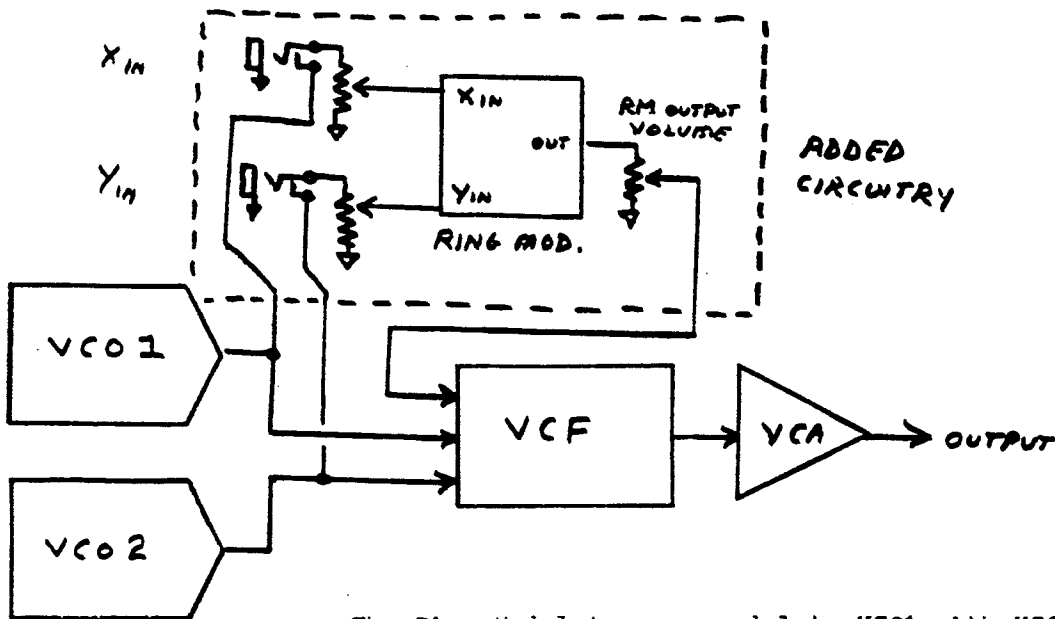

The Ring Modulator can modulate VCO1 with VCO2 or with external sources patched into the X and Y attenuated inputs.

M-20 VCO1, VCO2, NOISE SERIES OUTPUTS

Three stereo jacks are added to the back of the unit to allow access to the outputs of VCO1, VCO2 and noise for processing by external modifiers. The jacks are connected in such a way that if a stereo cable is plugged in, the tip of the stereo cable is the output of the respective module, and the ring is the input back into the VCF. This allows modifiers such as phase shifters, delay lines, fuzz boxes etc. to be placed in series between either VCO1, VCO2, or the noise and the VCF.

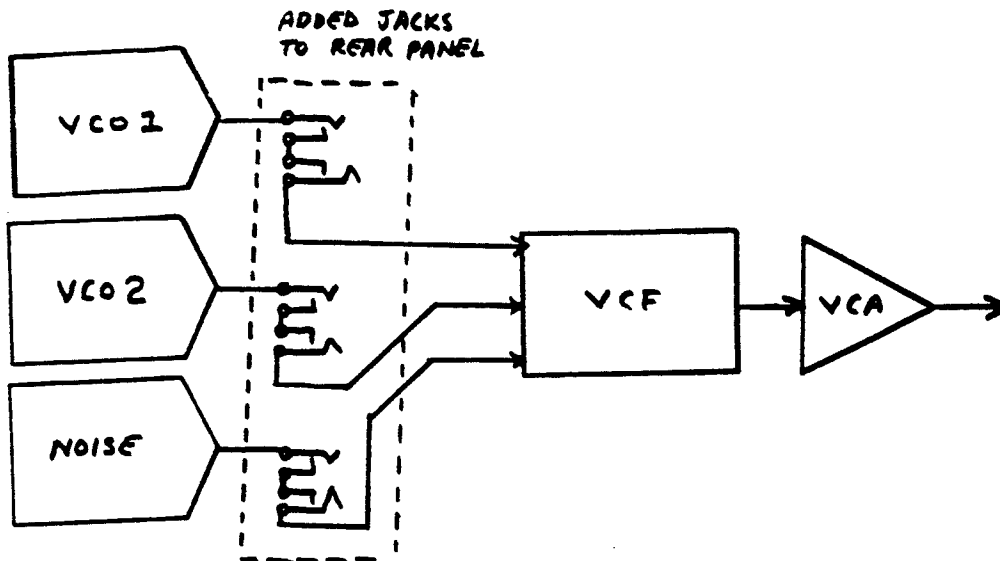

By adding these patching jacks, external modifiers can be connected in series with the sound sources.

M-21 VCF BYPASS SWITCHES FOR VCO1, VCO2, AND NOISE

Three miniature toggle switches are added to the panel to allow the noise, VCO1 and VCO2 modules to bypass the VCF and instead go directly to the VCA. This allows certain modules to be modified by the VCF and others to be unaffected, thus extending the ability to create complex timbres.

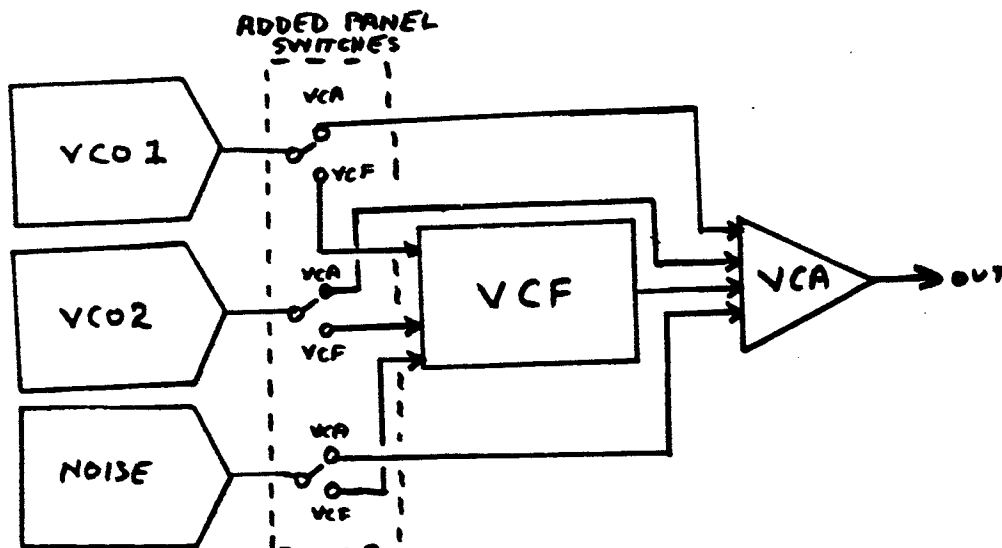

By adding these bypass switches, the sound sources can bypass the VCF and go directly to the VCA

M-22 INPUT/OUTPUT PATCHING SYSTEM

The outputs of the LFO sine, square, ADSR, AR, S&H, VCO1, VCO2 mixers and noise are brought to back panel jacks without disrupting their initial internal connections. This allows access to all of these modules for external processing. VCO1, VCO2, and VCF each are given an external extra modulation input for a total of 11 jacks.

These three inputs are connected in series with the first patch switch and modulation attenuator for VCO1, VCO2 and VCF. When a plug is inserted into one of these jacks, the mod source switch is disconnected and replaced by the external mod source. The attenuator normally corresponding to the disconnected mod source switch controls the external input mod depth. This mod is suggested for electronic music studio applications since it allows much more modulation capabilities and integrated processing of synthesizer signals with external modifiers.

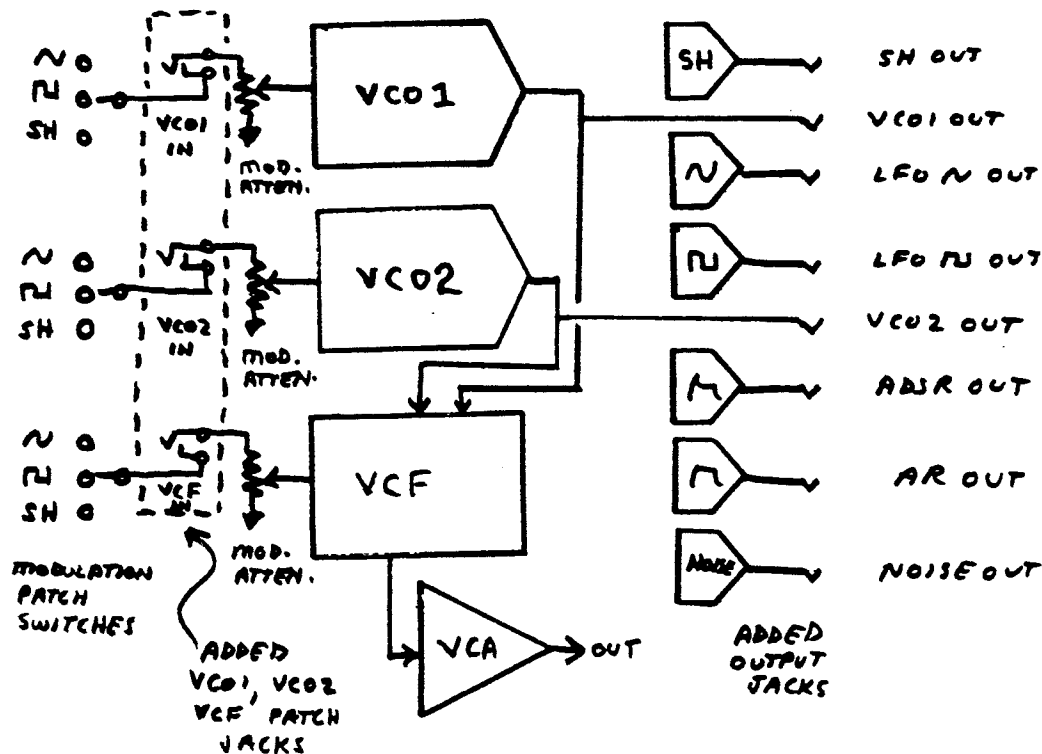

M-23 KNOBS

A set of knobs and applicator tool to update the A-1000 to SRM status.