

Fig. 49 Circuit Diagram of External Inputs

**Parts List for External Inputs**  
(1 required for 5600S; 1 required for 3800)

|               |             |                  |
|---------------|-------------|------------------|
| 5600S         | 3800        |                  |
| R1,2          | R1          | Min Res 820Ω     |
| R3,4          | R3          | Min Res 12k      |
| R5,6          | R5          | Min Res 150k     |
| R7,8          | R7          | Min Res 560k     |
| R9,10,20      | R9,20       | Min Res 3k3      |
| R11,12,13     | R11,13      | Min Res 100k     |
| R14,15,18     | R14,15,18   | Min Res 10k      |
| R16,19        | R16,19      | Min Res 1M       |
| R17           | R17         | Min Res 680k     |
| RV1,2         | RV1         | Pot Log 47k      |
| RV3           | RV3         | Pot Lin 10k      |
| C1,3          | C1          | Tant 1 μF 35V    |
| C2,4,10,11,12 | C2,10,11,12 | Tant 10 μF 16V   |
| C5,6          | C5,6        | Tant 4.7 μF 35V  |
| C7,9          | C7,9        | Ceramic 10pF     |
| C8            | C8          | Polyester 0.1 μF |
| IC1           | IC1         | LM381            |
| IC2,3         | IC2,3       | LM301A           |
| D1            | D1          | 1N4148           |
| SW1,2,3       | SW1         | Sub-Min Toggle A |

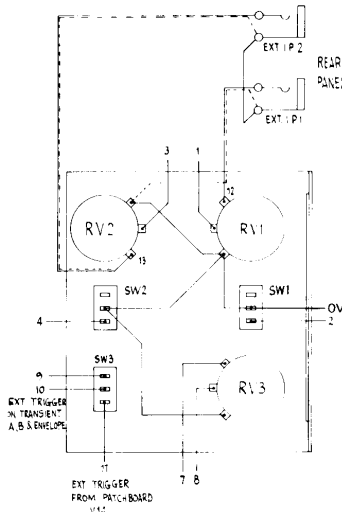

Fig. 50 Front Panel Wiring for External Inputs (5600S only)

**Also required**

- 1 Synth Ext I/P PCB
- 1 DIL Socket 14-pin
- 2 DIL Socket 8-pin
- 1 Wafercon Skt 8-way
- 8 Wafercon Terminals
- 2 Bolt 6BA 1/4in.
- 2 Nut 6BA
- 2 Shake 6BA

**Also required for 5600S only**

- 1 Ext I/P Mtg Bkt
- 13 Pin 2141
- 3 15mm Collet Knob Black
- 3 15mm Collet Nut Cover
- 2 15mm Collet Cap Yellow
- 1 15mm Collet Cap Blue

**Also required for 3800 only**

- 1 3800 Ext I/P Mtg Bkt
- 10 Pin 2141
- 2 15mm Collet Knob Black
- 2 15mm Collet Nut Cover
- 2 15mm Collet Cap Red

**Voltage Controlled Filter**

**Construction**

Assemble the two pcb's as shown in Fig. 51. They are identical. Fix the front panel components to the bracket then the pcb and interwire as shown in Fig. 53. Fix the assembled modules to the front panel.

**Voltage Controlled Filter — How It Works**

The voltage controlled filter consists of three main sections:—  
1. The buffer amplifier/mixer.  
2. A low-pass filter.  
3. A voltage controlled oscillator.

The buffer amplifier IC3 is used to give a level shift to the input signal and to provide

a constant 100k input impedance. A second input direct to the input of IC3 is used, in the 3800 synthesiser, for additional mixing.

The 4016 analogue switches have all their control inputs connected together and these switches may be regarded as a normal four pole active low-pass filter (two 2-pole in series). The filter has a gain of unity (output of IC3 to output of IC5) below the cut-off frequency and an ultimate slope of 24dB/octave above the cut-off frequency.

As well as an amplitude change with frequency there is also a change in phase relationship. Initially the output of the filter is 180° out of phase with the input (point E), and in phase when 6dB down. It

eventually moves 180° out of phase again as the frequency increases. The potentiometer RV3 and resistor R18 take part of the output signal and feed it back into the input of IC3. Below the cut-off frequency this causes the output to be attenuated, at the cut-off frequency the signal is boosted and above the cut-off it again starts to attenuate. This causes the output to peak in the region of the cut-off frequency and then drop suddenly above that frequency. The height of the peak is adjustable. If adjusted too high, the filter will oscillate.

To vary the cut-off frequency we must vary the four capacitors or the four resistors in these areas of the filter.

To obtain the two ranges we switch capacitors in or out and, to give the

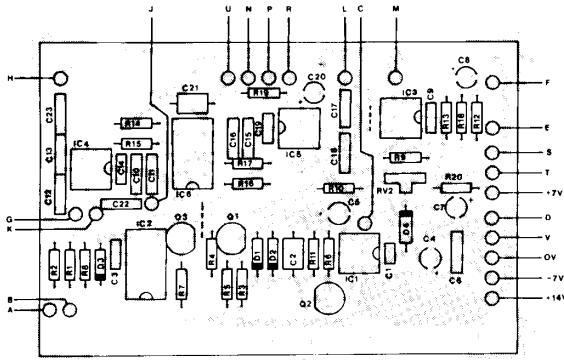

Fig. 51 Component Overlay for VCF

continuously variable range, we vary the resistors by switching them in and out at a fast rate but with a mark-space ratio which is variable.

By such switching the effective value of a resistor becomes:—

$$\frac{R \times \text{total time}}{\text{time on}}$$

and since on-time is always shorter than total time the resistance can vary from 'R' upwards. We obtain a variable mark-space ratio by using a monostable of about 200n sec triggered by a voltage controlled oscillator which is variable from 5kHz to about 1MHz. We therefore keep the on-time constant and vary the off-time.

The voltage-to-frequency converter does in fact have a linear relationship from about 10kHz to 1MHz. Frequencies below 20kHz, however, should not be used, as the chopping frequency will become audible.

A variable constant-current source is provided by IC1 and Q2, where the base-emitter voltage of Q2 is compensated by taking feedback from the emitter of Q2 to IC1. A further constant current source is provided by Q1. The current from Q1 can flow either via Q3 to ground (output of IC2/2), or through Q2 as well as into C2. The current provided by Q1 is higher than the maximum available through Q2 and thus C2 will be charged by a constant current (when IC2/2 is high) the value of which is determined by the input voltage.

The voltage on C2 is passed to the input of IC2/1 such that if this voltage is above approximately 7 volts the output of IC2/1 will be low (OV) whereas if the input voltage is less than 7 volts the output will be high (+14V).

In addition RV2 is provided to prevent the oscillator stopping on overvoltage and R11 is provided to prevent the oscillator stopping when there is a negative input voltage.

### 20 Setting-up Filters for 5600S

Connect +14V in turn to V7 and then to V8, and patch H7/V29 (then H8/V29) and connect a 'scope to this point. Turn RV2 fully towards R9, set range control to low, resonance to maximum and tune control fully anticlockwise. The filter should act as a very low frequency (inaudible) oscillator. Rotate the tune control clockwise and the frequency will increase and then it may drop slightly. Continue until the control is fully clockwise. Adjust RV2 until oscillation just starts to decrease again. (If it did drop slightly when it was being increased, it may jump up in frequency on adjusting RV2 before starting to decrease.)

### 12 Setting-up Filter for 3800

Disconnect the wire from point 'A' on the filter pcb and apply +14V to this point. Turn

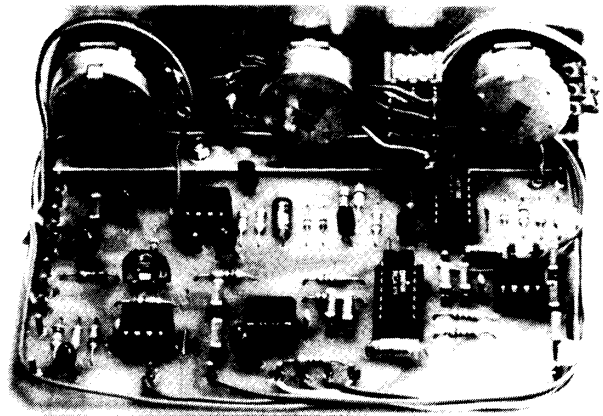

VCF

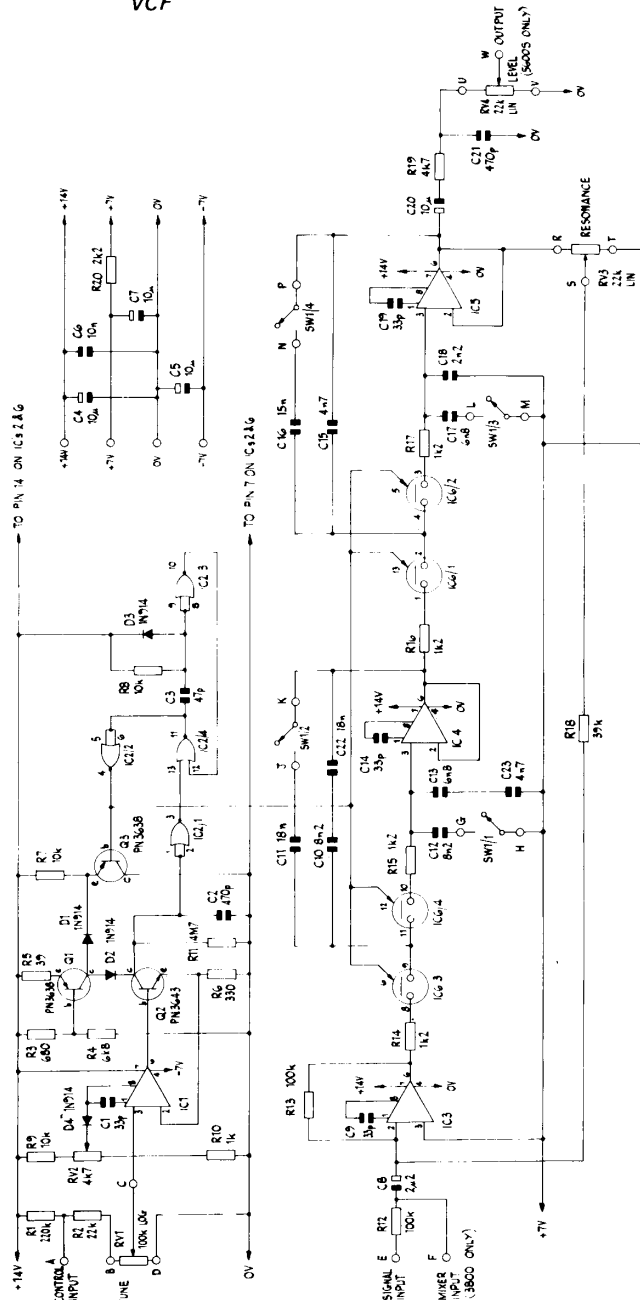

Fig. 52 Circuit Diagram of VCF

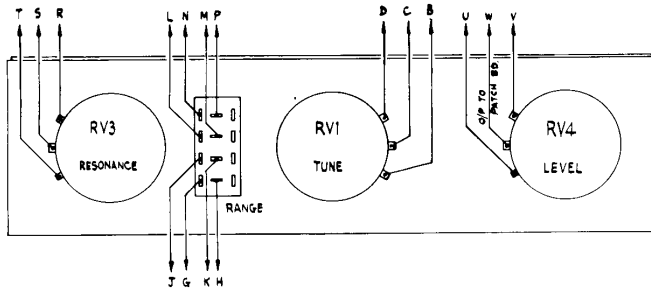

Fig. 53 Front Panel Wiring for VCF (5600S only)

RV2 fully towards R9, set range control to low, resonance to maximum and tune control fully anticlockwise. The filter should act as a very low frequency (inaudible) oscillator. Rotate the tune control clockwise and the frequency will increase and then it may drop slightly. Continue until the control is fully clockwise. Adjust RV2 until oscillation just starts to decrease again. (If it did drop slightly when it was being increased, it may jump up in frequency on adjusting RV2 before starting to decrease.) Disconnect +14V and reconnect the wire from point A on FPC12 to point 'A' on pcb.

**Parts List for VCF**

(2 required for 5600S; 1 required for 3800)

- |    |              |              |                      |
|----|--------------|--------------|----------------------|
| R1 | Min Res 220k | R5           | Min Res 39Ω          |
| R2 | Min Res 22k  | R6           | Min Res 330Ω         |
| R3 | Min Res 680Ω | R7,8,9       | Min Res 10k          |
| R4 | Min Res 6k8  | R10          | Min Res 1k           |
|    |              | R11          | Min Res 4M7          |
|    |              | R12,13       | Min Res 100k         |
|    |              | R14,15,16,17 | Min Res 1k2          |
|    |              | R18          | Min Res 39k          |
|    |              | R19          | Min Res 4k7          |
|    |              | R20          | Min Res 2k2          |
|    |              | C1,9,14,19   | Ceramic 33pF         |
|    |              | C2,21        | Polystyrene 470pF    |
|    |              | C3           | Ceramic 47pF         |
|    |              | C4,5,7,20    | Tant 10μ F 16V       |
|    |              | C6           | Carbonate 0.01 μ F   |
|    |              | C8           | Tant 2.2 μ F 35V     |
|    |              | C10,12       | Carbonate 0.0082 μ F |
|    |              | C11,22       | Carbonate 0.018 μ F  |
|    |              | C13,17       | Carbonate 0.0068 μ F |
|    |              | C15,23       | Carbonate 0.0047 μ F |
|    |              | C16          | Carbonate 0.015 μ F  |
|    |              | C18          | Carbonate 0.0022 μ F |

- RV1 Pot Log 100k
- RV2 Vert S-Min Preset 4k7
- RV3 Pot Lin 22k
- RV4 (for 5600S only) Pot Lin 22k
- Q1,3 MPS3638
- Q2 PN3643
- IC1,3,4,5 LM301A
- IC2 4001BE
- IC6 4016BE
- D1,2,3,4 1N4148
- SW1 4p S-M Toggle

**Also required**

- 1 3600 VCF PCB
- 2 DIL Socket 14-pin
- 4 DIL Socket 8-pin
- 1 Wafercon Socket 8-way
- 8 Wafercon Terminals
- 23 Veropin 2141
- 2 Bolt 6BA 1/2in.
- 2 Nut 6BA
- 2 Shake 6BA

**Also required for 5600S only**

- 1 Synth VCF Mtg Bkt
- 3 15mm Collet Knob Black
- 3 15mm Collet Nut Cover
- 2 15mm Collet Cap Grey (for VCF 1 only)
- 1 15mm Collet Cap Blue (for VCF 1 only)
- 2 15mm Collet Cap Yellow (for VCF 2 only)
- 1 15mm Collet Cap Blue (for VCF 2 only)

**Also required for 3800 only**

- 2 15mm Collet Knob Black
- 2 15mm Collet Nut Cover
- 2 15mm Collet Cap Red
- 1 3600 VCF Mtg Bkt

**Headphone Amplifiers Construction**

Construct two 8W Amp Kits. Fit and solder the pins to the pcb, then the other components, taking care to ensure that the PC Electrolytics are inserted the right way round. Solder the IC to the pcb then smear the metal tab with Thermaph. Bolt the heatsink to the pcb, then bend the IC over

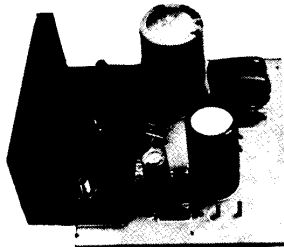

Headphone Amp

and bolt it to the heatsink. Fix the two amps to the base of the cabinet using two No. 6 self-tapping screws in the positions shown in the internal layout photograph.

**Parts List for 8W Amp Kit**

The 8W Amp Kit should contain the following parts.

- |      |                       |
|------|-----------------------|
| R1   | Min Res 18k           |
| R2   | Min Res 220Ω          |
| R3   | Min Res 5.6Ω          |
| C1   | PC Elect 10 μ F 40V   |
| C2   | PC Elect 470 μ F 16V  |
| C3,4 | Polyester 0.22 μ F    |
| C5   | PC Elect 1000 μ F 16V |
| IC1  | LM383                 |

**Also included**

- 1 8W Hi-Fi Heatsink

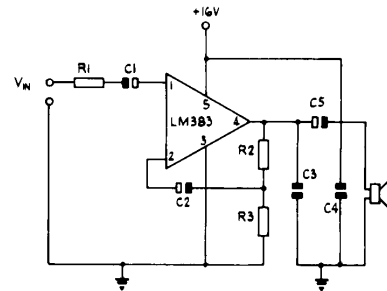

Circuit Diagram of Headphone Amp

- 1 8W Amp PCB
- 6 Pins 2145
- 3 Bolt 4BA 1/2in.
- 3 Nut 4BA

**Completing the Front and Rear Panels**

Fix the foot pedal, foot switch and echo controls to the mixer bracket and front panel. Fix the three 'output' controls and switch, and the three controls and socket immediately above these to the front panel directly. Fix the patchboard using four 6BA 1/2in. bolts, three fitted with tags to anchor an earth bar made of 20swg strapping wire as shown in the photograph. Cut down all the spindles and fit the knobs as shown in the colour photograph. Fit the components to the rear panel as shown in Fig. 54 and fix the panel to the cabinet. Note that a boot should be fitted to the fuseholder and mains plug.

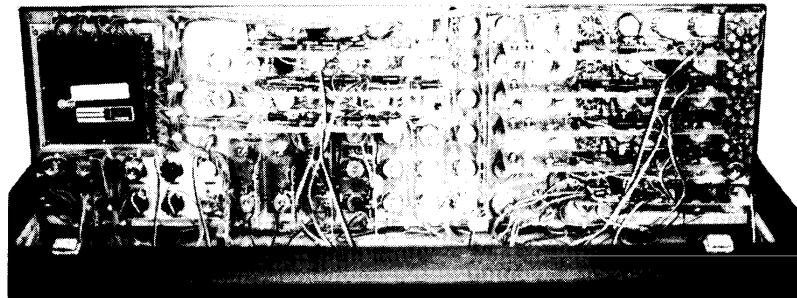

5600S Front Panel

## Interwiring

Carefully follow through the wiring schedule set out in Table 2 picking out first all the wires that interconnect on the front panel. Now put the front panel on the pins of the hinges and screw the hinges to the cabinet so that the pin locates in the blind hole in the cabinet. Complete the wiring shown in Table 2, then connect up all the wiring shown in Fig. 54.

Connect up the keyboard controller to the front panel as shown in Fig. 8. Wire the reverb and phase pcb to the front panel as shown in Fig. 55. Then connect up the other wires shown in Fig. 55. Connect up the wires to the foot pedal, foot switch and echo controls as shown in Fig. 56. Finally wire up the headphone amplifiers as shown in Fig. 57.

## Other Parts Required For 5600S Only

- 1 5600S Cabinet
- 1 5600S Front Panel
- 2 C/S Panel Screw 4BA 1in. (for front panel)
- 2 4BA Cup Washer
- 2 4600 Hinge
- 4 Self-Tapper No. 4 3/8in. (for hinge)
- 1 Large Patchboard
- Large Patch Plugs (as required)
- 300mm Strapping Wire 18swg
- 4 Bolt 6BA 1/2in. (for patchboard)
- 7 Nut 6BA
- 3 Tag 6BA
- 1 48-note Keyboard
- 48 Contact Block 1WG
- 8 Earth Bar
- 4 KB Mounting Strip
- 10 Self-Tapper No. 6 1/2in. (for keyboard)
- 2 8W Amp Kit
- 4 Self-Tapper No. 6 1/2in. (for 8W Amp kit)
- 1 5600S Rear Panel
- 10 Jack Skt Brk (SK1 to 6,8,9,11,12)
- 2 Jack Skt Sto (SK7 and Headphone socket)
- 1 Multisocket 8-way (SK10)
- 1 Springlatch 8-way
- 4 Bolt 6BA 1/2in. (for Multisocket)
- 4 Nut 6BA
- 8 Self-Tapper No. 4 3/8in. (for rear panel)
- 1 Tag 4BA
- 1 roll Strapping Wire 22swg
- 1 Systoflex 1mm White
- 1 Systoflex 2mm Yellow
- 2pk Double Bubble Sachet
- 4pk Solder D622
- 1 Small Thermpath
- 1pk Wire 11C
- 30m Cable Twin
- 5m Ribbon Cable 20-Way

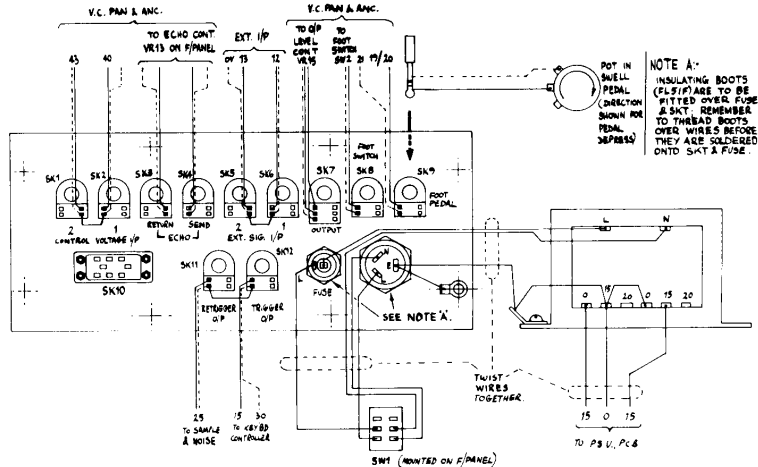

Fig. 54 Rear Panel Wiring (5600S only)

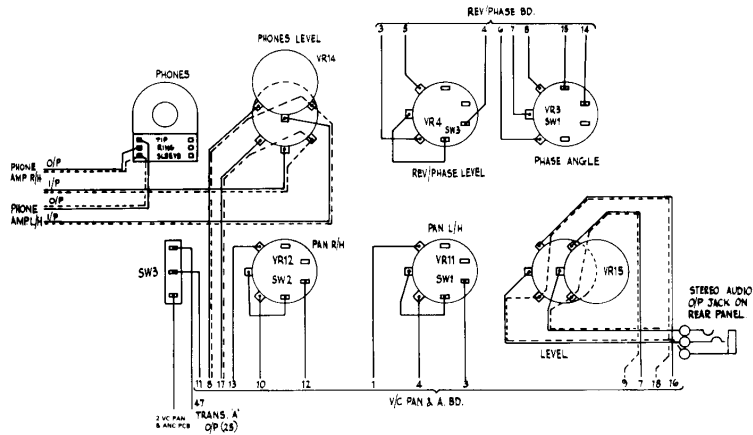
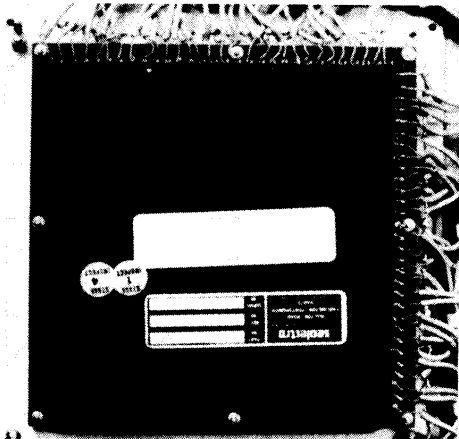

Fig. 55 Reverb, Phase and Output Controls Wiring



Patchboard showing connection of screens to wire straps fixed to tags on fixing screws.

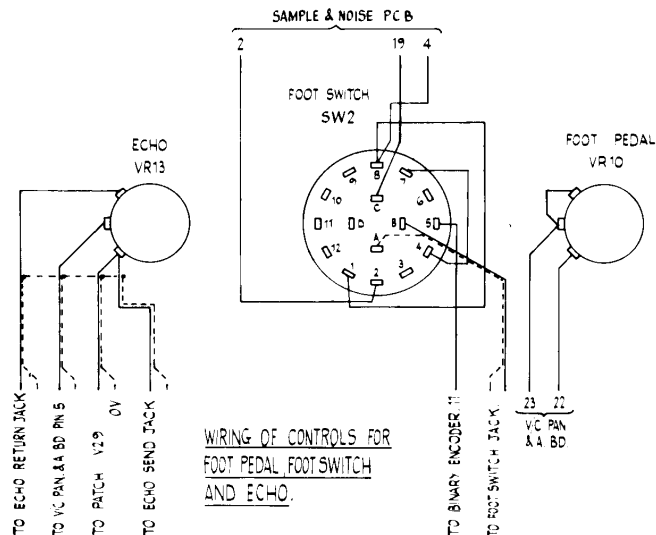

Fig. 56 Wiring of Controls for Foot Pedal, Foot Switch and Echo

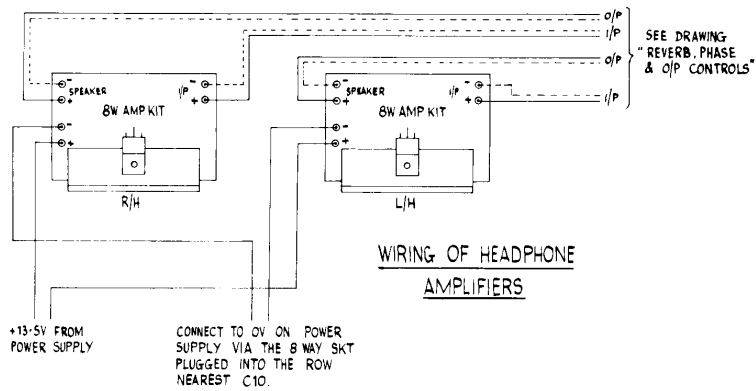

Fig. 57 Wiring of Headphone Amplifiers (5600S only)

## CONSTRUCTION 3800



### Power Supply

This board is the same as that in the 5600S synthesiser. Follow the construction details for the 5600S. There are sufficient plugs in the 3800 for every board individually except the binary encoder which is powered from the keyboard controller.

### Keyboard and Binary Encoder

This board is the same as that in the 5600S synthesiser. Follow the construction details for the 5600S.

### Keyboard Controller

This board is the same as that in the 5600S synthesiser. Follow the construction details for the 5600S.

### Oscillator

The oscillators in the 3800 are identical to those in the 5600S except that there are only two in the 3800. As in the 5600S, oscillator 2 is wired differently from oscillator 1. When wiring the bracket mounted components as per Figs. 12 and 13 omit the wires between SW4 and pins 20 and 21 on both oscillators. Fix the oscillators to the front panel.

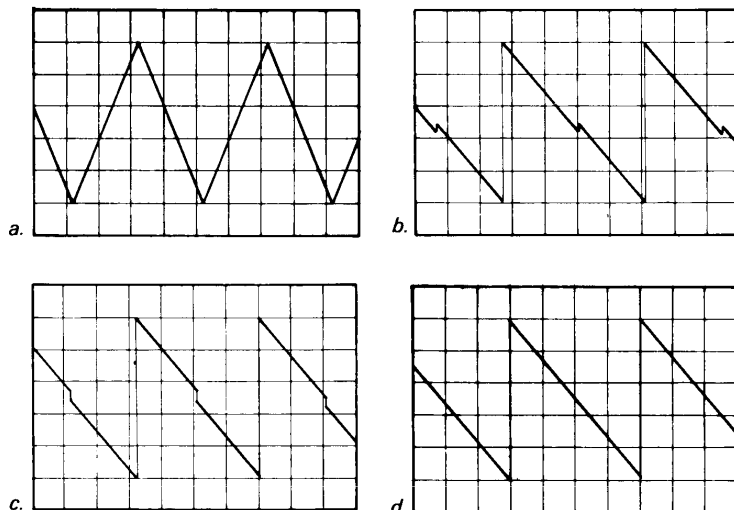

Fig. 58 Setting-up Oscillators

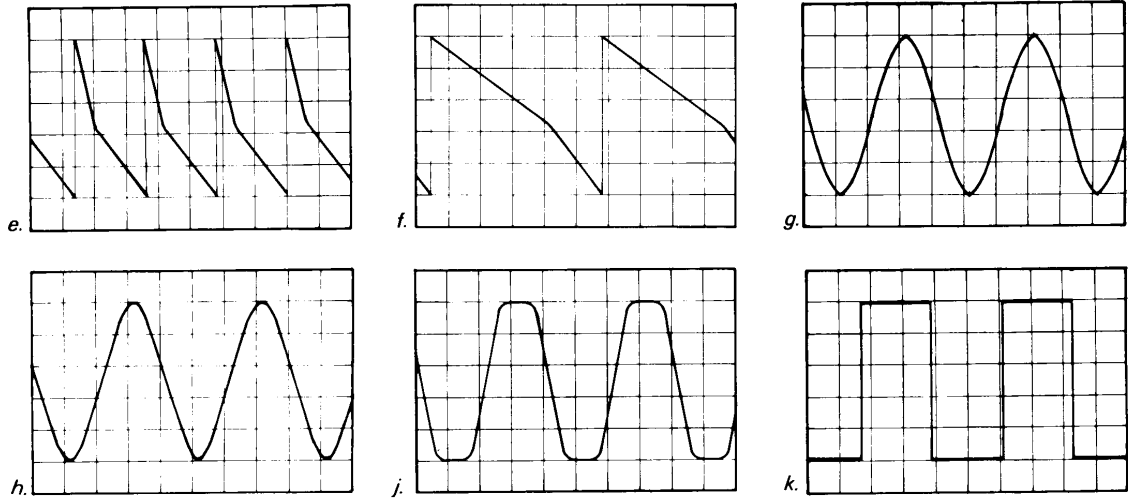

Fig. 58 Setting-up Oscillators

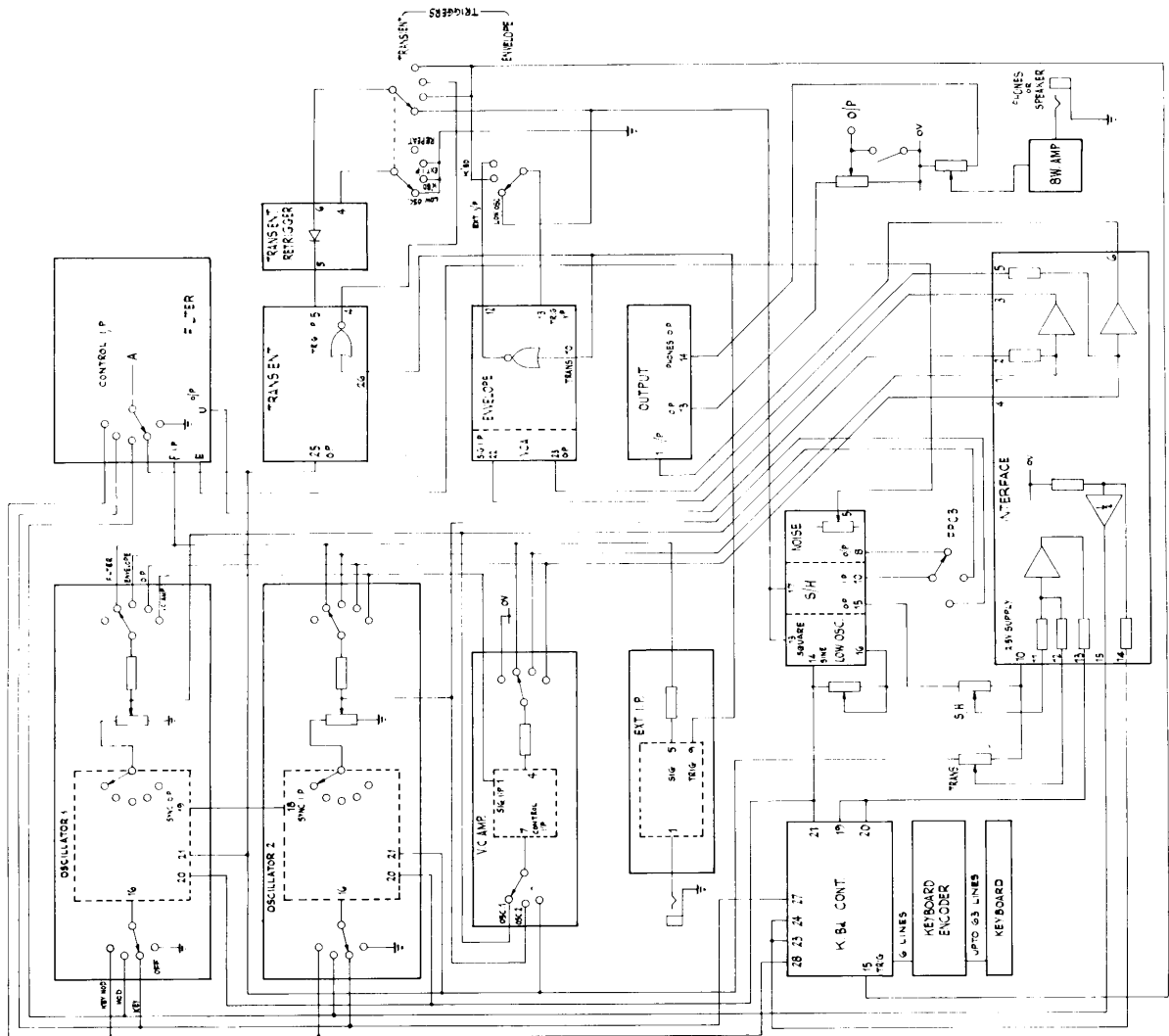

Fig. 59 Block Schematic of 3800

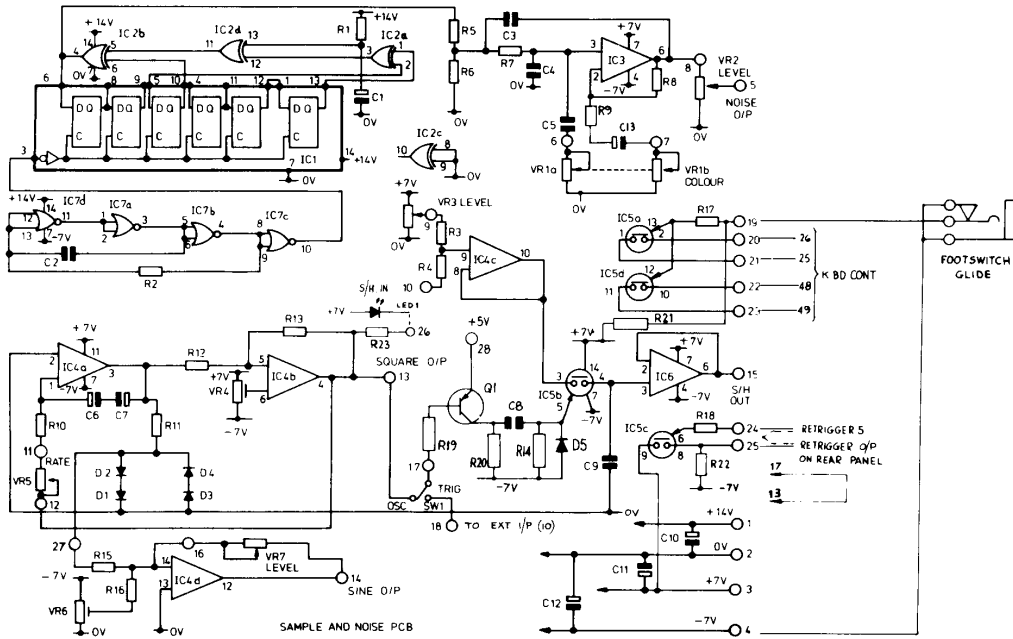

Fig. 60 Circuit Diagram of Sample and Noise (3800 only)

**Sample and Noise**

This board is the same as that in the 5600S synthesiser. Follow the construction details for the 5600S until the pcb is finished. Then fix the pcb and the front panel controls to the bracket, but do not proceed with any interwiring yet. The circuit in the 3800 is different from the 5600S and is shown in Fig. 60. Fix the bracket to the front panel.

**External Input**

The external input is provided so that other electronic instruments may be fed into the synthesiser in order to obtain new and different sounds. A trigger pulse is generated from the external instrument's signal, thus allowing the transient generators to be triggered.

Assemble the pcb as shown in Fig. 48, but omit: R2, R4, R6, R8, R10, R12, C3, C4 and C6. Pins 3, 4 and 6 are not required. Fix the front panel controls and the pcb to the bracket and interwire as shown in Fig. 61. Fit the assembly to the front panel.

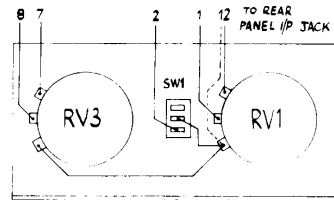

Fig. 61 Front Panel Wiring for External Inputs (3800 only)

**Interface Construction**

Assemble the pcb with the aid of the component overlay Fig. 62. Fix the front panel controls and the pcb to the bracket. Fix the assembly to the front panel.

**Parts List for Interface**  
(1 required for 3800 only)

- R1,2,3,4 Min Res 100k
- R5 Min Res 82k
- R6 Min Res 18k
- R7,8,9,12,13 Min Res 22k
- R10,11 Std Res 22k
- C1,2 Tant 10 μF 25V
- VR1,2 Pot Lin 22k
- IC1 4136
- IC2 μ A741C 8-pin DIL

**Also required**

- 1 3800 Interface PCB
- 1 Interface Mtg Bkt

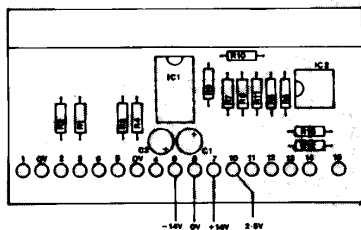

Fig. 62 Component Overlay for Interface

- 1 DIL Socket 14-pin
- 1 DIL Socket 8-pin
- 1 Wafercon Socket 8-way
- 8 Wafercon Terminals
- 17 Veropin 2141
- 2 15mm Collet Knob Black

- 2 15mm Collet Nut Cover
- 2 15mm Collet Cap Grey
- 2 Bolt 6BA 1/4in.
- 2 Nut 6BA
- 2 Shake 6BA

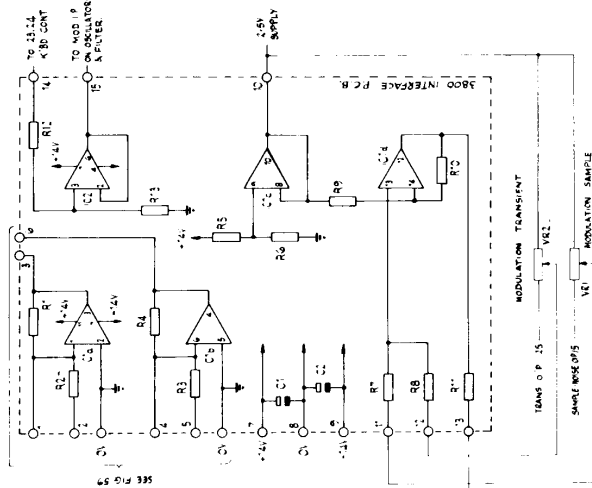

Fig. 63 Circuit Diagram of Interface

### VCA

Assemble the VCA pcb using the component overlay Fig. 25 taking care with the orientation of the polarised components. Mount the front panel components and the pcb to the bracket and fix to the front panel with FPC10 and FPC11 (see Fig. 69).

### Voltage Controlled Filter

Assemble the pcb as shown in Fig. 51. Fix the front panel components and the pcb to the bracket and interwire as shown in Fig. 64. Fix the assembly to the front panel.

### Transient A

Assemble the transient 2 pcb as shown in Fig. 29 and the transient retrigger pcb as shown in Fig. 33. Fix the two pcb's and the front panel controls to the bracket and interwire as shown in Fig. 31 omitting the

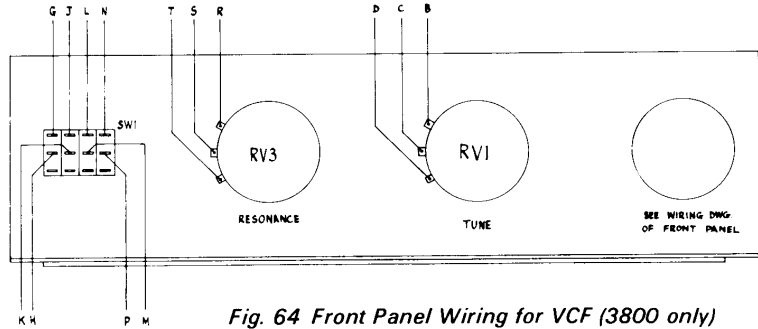

Fig. 64 Front Panel Wiring for VCF (3800 only)

wiring to SW1 and SW3. Fix the assembly to the front panel.

### Envelope

Assemble the 'transient' pcb as shown in

Fig. 20 and the VCA pcb as shown in Fig. 22. Fix the pcb's and the front panel controls to the bracket and interwire as shown in Fig. 24 omitting the wiring to SW2. Fix the assembly to the front panel.

### Output Module Construction

Assemble the pcb as shown in Fig. 65. Fix the pcb and the front panel components to the bracket and fix the bracket to the front panel. Fix the spring line to the cabinet as shown in the internal layout photograph. The spring line should be mounted on two rubber grommets. Wire the spring line to the output module as shown in Fig. 67.

### Output Module — How It Works

This pcb can be broken down into four sections as follows:—

- Input Buffer
- Equaliser
- Reverberation
- Output Amplifier

The input buffer (IC1) has a 200k  $\Omega$  input impedance and gives an attenuation of 6dB ( $\frac{1}{2}$ ). The attenuation is required to prevent

clipping in the equaliser output stage.

The output from the buffer is directly coupled to the input of the equaliser stage. This stage is a little unusual, since the equalising networks are arranged to vary the negative feedback. If we consider one section with the others disconnected, at the resonant frequency of the series LCR combination the impedance of the entire network will be equal to 680ohms. Either

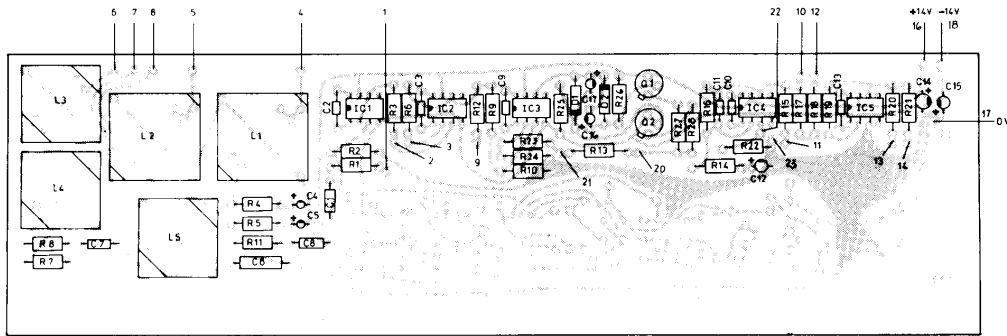

Fig. 65 Component Overlay for Output Module

side of resonance the impedance of the network will increase (with a slope dependent on the Q of the network), due to uncancelled inductive reactance above resonance and uncancelled capacitive reactance below resonance. We can

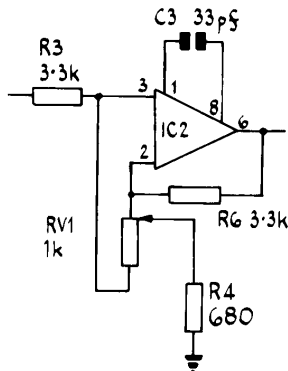

Fig. A Equivalent circuit of the equaliser with the potentiometer set for maximum boost at the resonant frequency of the network.

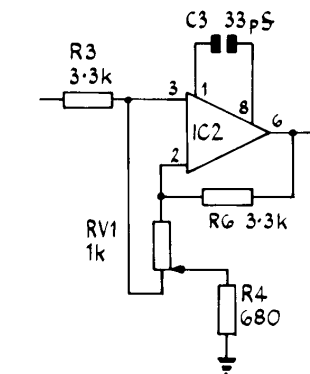

Fig. B Equivalent circuit of the equaliser with the potentiometer set for maximum cut at the resonant frequency of the network.

therefore represent the equaliser stage with equivalent circuits as reproduced here. These circuits consider only one network is in circuit, the input signal frequency is the resonant frequency of the

network, and the resistance of the inductor is negligible.

With the slider of the potentiometer at the top end (Fig. A) we have 680ohms to the zero volt line from pin 2 of IC2, and a 1kohm between pin 3 and pin 2. The IC will

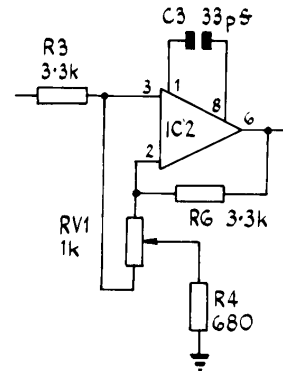
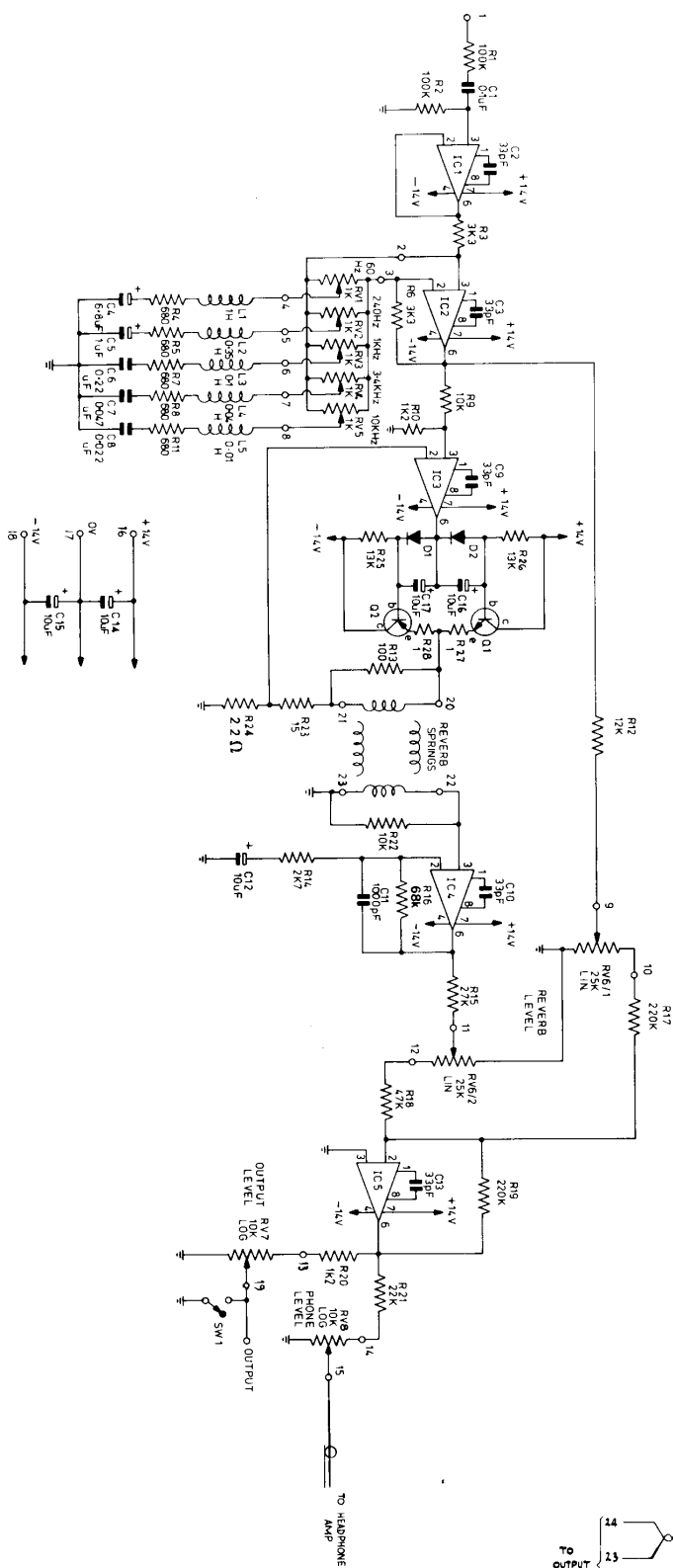

Fig. C Equivalent circuit of the equaliser with the potentiometer set for unity gain regardless of frequency.



Fig. 66 Circuit Diagram of Output Module



act due to the feedback to keep the potential between pins 2 and 3 virtually zero, thus there is zero current through RV1. The voltage on pin 3 (IC2) is therefore equal to the output of the mixer since there is virtually no current through and no voltage drop across R3.

The output of IC2 in this case is approximately the input signal times  $(R6 + 680)/680$ ohms, indicating a gain of about 15dB. If the slider is at the other end of the potentiometer (Fig. B) the signal appearing at pin 3 and thus also at pin 2 is about 0.2 of the output of the previous stage due to the voltage division of R3 and the 680  $\Omega$ . There is still zero current through RV1 and also zero current through R6 since there is no path. The output voltage is therefore the same as that at pin 2, which happens to be about 0.2 times the output of the previous stage. The gain is therefore 0.2 or -13dB.

With all networks in circuit, the maximum boost and cut will be reduced, but a range of  $\pm 10$ dB is still available. With the wiper of the potentiometers set midway (Fig. C), the gain will be unity regardless of frequency, due to the symmetry of the entire network.

The equaliser output is fed into the reverb drive circuit (IC3, Q3, Q4). The reverb is connected in the feedback of the IC in such a way that the drive is mostly constant current and not constant voltage. This drive method provides a more uniform frequency response. The output of the reverb is a very low amplitude signal which is amplified by IC4. The output of IC4 and the output of the equaliser (IC2) both go to RV6 which selects the percentage of each required.

The final amplifier, IC5, amplifies the output of RV6 and applies it to RV8 which adjusts the output level to the main amplifier. The output of IC5 also goes to the headphone amplifier.

#### 4 Setting-up Output Module

Switch oscillator 1 to output and listen either on main output or on phones. Check that the output module facilities all work correctly (i.e. reverberation and equaliser).

#### Parts List for Output Module (1 required for 3800 only)

- R1,2 Min Res 100k
- R3,6 Min Res 3k3
- R4, 5, 7, 8, 11 Min Res 680  $\Omega$
- R9, 22 Min Res 10k
- R10, 20 Min Res 1k2
- R12 Min Res 12k
- R13 Min Res 100  $\Omega$
- R14 Min Res 2k7
- R15 Min Res 27k
- R16 Min Res 68k
- R17, 19 Min Res 220k
- R18 Min Res 47k
- R21 Min Res 22k
- R23 Min Res 15  $\Omega$
- R24 Min Res 2.2  $\Omega$
- R25, 26 Std Res 13k
- R27, 28 Std Res 1  $\Omega$

- C1 Polyester 0.1  $\mu$  F
- C2, 3, 9, 10, 13 Ceramic 33pF
- C4 Tant 6.8  $\mu$  F 35V

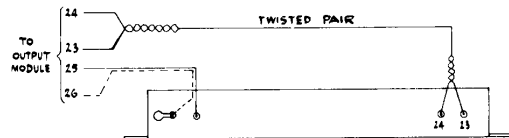

Fig. 67 Wiring of Short Spring Line

- C5 Tant 1  $\mu$  F 35V
- C6 Polyester 0.22  $\mu$  F
- C7 Polyester 0.047  $\mu$  F
- C8 Polyester 0.022  $\mu$  F
- C11 Polystyrene 1000pF
- C12,14,15,16,17 Tant 10  $\mu$  F 25V

- RV1,2,3,4,5 Pot Lin 1k
- RV6 Dual Pot Lin 25k
- RV7,8 Pot Log 10k

- Q1 2N2219
- Q2 2N2905
- IC1,2,3,4,5 LM301A
- D1,2 1N4148

- SW1 Sub-Min Toggle A
- L1 GE Coil L11
- L2 GE Coil L12
- L3 GE Coil L6
- L4 GE Coil L14
- L5 GE Coil L15

**Also required**

- 1 Output Stage PCB
- 1 Trans 1/Env Mtg Bkt
- 1 Short Spring Line
- 2 Self-Tapper No. 6 1/2in.
- 2 Grommet Small
- 5 DIL Socket 8-pin
- 1 Wafercon Socket 8-way
- 8 Wafercon Terminals
- 21 Veropin 2141
- 2 Bolt 6BA 1/4in.
- 2 Nut 6BA
- 2 Shake 6BA
- 8 15mm Collet Knob Black
- 8 15mm Collet Nut Cover
- 5 15mm Collet Cap Grey
- 1 15mm Collet Cap Black
- 1 15mm Collet Cap Blue
- 1 15mm Collet Cap Red

**Headphone Amplifier Construction**

This board is the same as that in the 5600S synthesiser (except that there is only one). Follow the construction details for the 5600S and then fix the complete assembly to the cabinet in the position shown in the internal layout photograph. Wire up the amplifier as shown in Fig. 68.

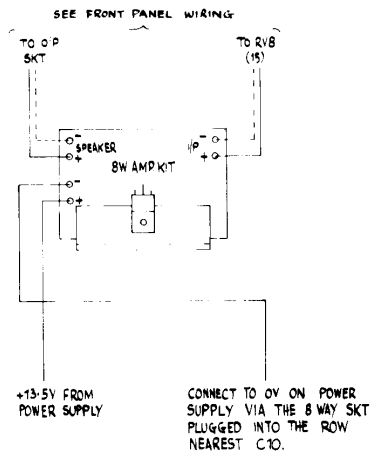

**Fig. 68 Wiring of Headphone Amplifier (3800 only)**

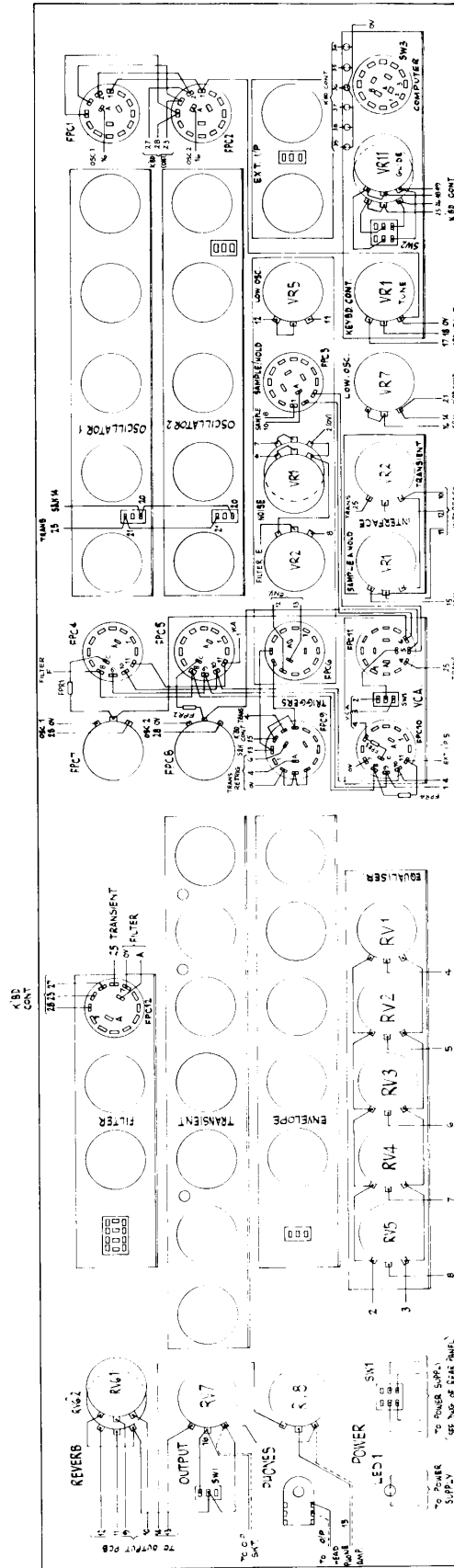

**Fig. 69 Wiring of Front Panel**

## Completing the Front and Rear Panels

Fix the rest of the components to the front and rear panels. Carefully wire the front panel as shown in Fig. 69 and the rear panel as shown in Fig. 70. Cut down all the spindles and fit the knobs as shown in the colour photographs. Fix the rear and front panels to the cabinet. Note that a boot should be fitted to the fuseholder and mains plug.

## Other Parts Required For 3800 Only

- 1 3800 Cabinet
- 1 3800 Front Panel
- 6 Rd Woodscrew No. 4 Black 1/2in. (for front panel)
- 4 Rotary Sw 4 (FPC 1,2,6,9)
- 2 Rotary Sw 3 (FPC 3,11)
- 4 Rotary Sw 6 (FPC 4,5,10,12)
- 2 Pot Lin 22k (FPC 7,8)
- 4 Min Res 100k (FPR 1,2,3,4)
- 12 15mm Collet Knob Black
- 5 15mm Collet Indicator
- 7 15mm Collet Nut Cover
- 2 15mm Collet Cap Black
- 3 15mm Collet Cap Blue
- 4 15mm Collet Cap Green
- 2 15mm Collet Cap Red
- 1 15mm Collet Cap Yellow
- 1 48-note Keyboard
- 48 Contact Block 1WG
- 8 Earth Bar
- 4 KB Mounting Strip
- 10 Self-Tapper No. 6 1/2in. (for keyboard)
- 1 8W Amp Kit
- 2 Self-Tapper No. 6 1/2in. (for 8W Amp kit)
- 1 3800 Rear Panel
- 6 Jack Skt Brk (SK1,2,3,4,6,7)
- 1 Multisocket 8-way (SK5)
- 1 Springlatch 8-way
- 4 Bolt 6BA 1/2in. } (for Multisocket)
- 4 Nut 6BA } (for Multisocket)
- 8 Self-Tapper No. 6 3/4in. } (for rear panel)
- 1 Tag 4BA }

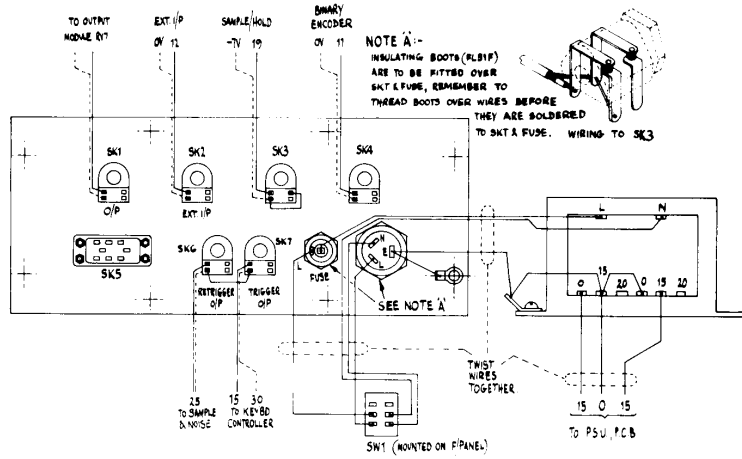
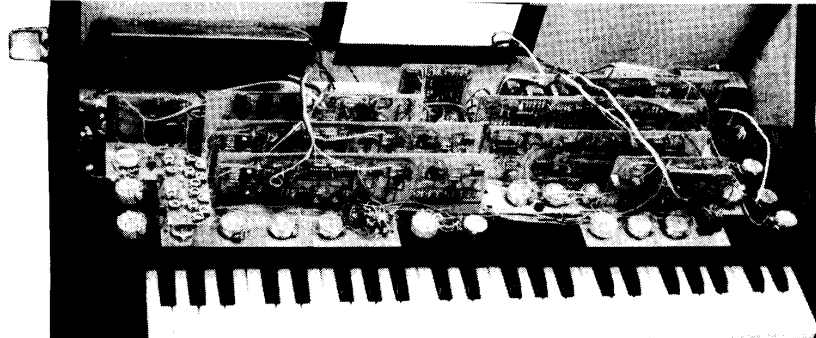

Fig. 70 Wiring of Rear Panel (3800 only)



3800 Front Panel

- 1 Jack Skt Sto (for headphones)
- 1 roll Strapping Wire 22swg
- 1 Systoflex 1mm White
- 1 Systoflex 2mm Yellow
- 2pk Double Bubble Sachet
- 3pk Solder D622
- 1 Small Thermpath
- 1 Foot Sw
- 1 Adaptor A (for Foot Sw)
- 1pk Wire 11C
- 15m Cable Twin
- 4m Ribbon Cable 20-Way

## Index

Construction of the 5600S should be carried out in the following order.

|                                | Page |
|--------------------------------|------|
| Power supply                   | 8    |
| Keyboard & Binary encoder      | 9    |
| Keyboard controller            | 10   |
| Oscillator                     | 17   |
| Mixer                          | 20   |
| Sample & noise                 | 22   |
| Envelope                       | 23   |
| VCA                            | 26   |
| Transient A & B                | 27   |
| Reverb & phase                 | 29   |
| VC pan & anc.                  | 30   |
| Joy lever                      | 34   |
| External inputs                | 35   |
| VCF                            | 36   |
| Headphone amps                 | 38   |
| Completing front & rear panels | 38   |
| Interwiring                    | 39   |

Construction of the 3800 should be carried out in the following order.

|                           | Page |
|---------------------------|------|
| Power supply              | 40   |
| Keyboard & Binary encoder | 40   |
| Keyboard controller       | 40   |
| Oscillator                | 40   |
| Sample & Noise            | 42   |
| External input            | 42   |
| Interface                 | 42   |
| VCA                       | 43   |

|                               |    |
|-------------------------------|----|
| VCF                           | 43 |
| Transient A                   | 43 |
| Envelope                      | 43 |
| Output module                 | 43 |
| Headphone amp                 | 45 |
| Completing front & rear panel | 46 |

Setting-up the 5600S should be carried out in the following order.

|                                    | Page |
|------------------------------------|------|
| 1 Power supply                     | 8    |
| 2 Oscillators                      | 17   |
| 3 Keyboard controller              | 12   |
| 4 Transient A & B                  | 27   |
| 5 Retrigger                        | 28   |
| 6 Mixer                            | 21   |
| 7 Voltage controlled panning       | 33   |
| 8 Tuning by zero-beat method       | 18   |
| 9 Oscillators 2, 3 and 4 continued | 18   |
| 10 Keyboard controller continued   | 13   |
| 11 Exponential converter           | 34   |
| 12 Inverter                        | 33   |
| 13 External control voltage inputs | 33   |
| 14 Foot pedal                      | 33   |
| 15 Joystick                        | 35   |
| 16 Envelope                        | 25   |
| 17 VCA                             | 26   |
| 18 Noise generator                 | 22   |
| 19 Low oscillator                  | 22   |
| 20 VCF                             | 37   |
| 21 Reverb & phase                  | 29   |

Setting-up the 3800 should be carried out in the following order.

|                | Page |
|----------------|------|
| 1 Power supply | 8    |

|                                 |    |
|---------------------------------|----|
| 2 Oscillators                   | 18 |
| 3 Keyboard controller           | 16 |
| 4 Output module                 | 44 |
| 5 Tuning by zero-beat method    | 20 |
| 6 Oscillator 2 continued        | 20 |
| 7 Keyboard controller continued | 16 |
| 8 Transient                     | 28 |
| 9 Retrigger                     | 28 |
| 10 Envelope                     | 26 |
| 11 VCA                          | 26 |
| 12 VCF                          | 37 |
| 13 Noise generator              | 22 |
| 14 Low oscillator               | 23 |

The following is a list of where other non-specific information may be found in this book.

|   | Page  |
|---|-------|
| Block schematic of 5600S                            | 5     |
| Block schematic of 3800                             | 41    |
| Specification of 3800                               | 6     |
| Note about adjusting presets                        | 13    |
| Table 1   | 14    |
| Table 2   | 14    |
| Table 3   | 16    |
| 5600S internal layout                               | 16    |
| 3800 internal layout                                | 40    |
| Photographs of keyboard and contact blocks          | 16    |
| Other parts required for 5600S                      | 39    |
| Reverb, phase and output controls wiring            | 39    |
| Wiring of foot pedal, foot switch and echo controls | 39    |
| Wiring of headphone amps for 5600S                  | 40    |
| Fig. 58   | 40,41 |