

Fig. 21 Circuit Diagram of Transient Used In Envelope

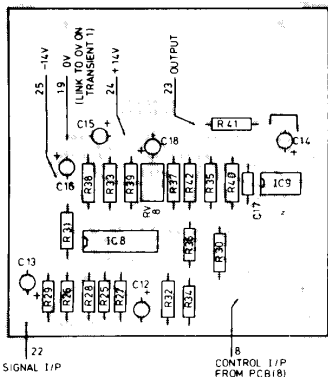

Fig. 22 Component Overlay for VCA Used In Envelope

- SW1 Sub-Min Toggle A
- SW2 (for 5600S only) Sub-Min Toggle A

- Also required**
- 1 Synth Trans Gen 1 PCB
 - 1 Synth VCA PCB
 - 1 Trans Gen 1/Env Bkt
 - 1 Wafercon Skt 8-way
 - 8 Wafercon Terminals
 - 28 Veropin 2141
 - 5 DIL Socket 14-pin
 - 4 DIL Socket 8-pin
 - 4 Bolt 6BA 1/4in.
 - 4 Nut 6BA
 - 4 Shake 6BA
 - 5 15mm Collet Knob Black
 - 5 15mm Collet Nut Cover
 - 5 15mm Collet Cap Grey (for 5600S only)
 - 5 15mm Collet Cap Red (for 3800 only)

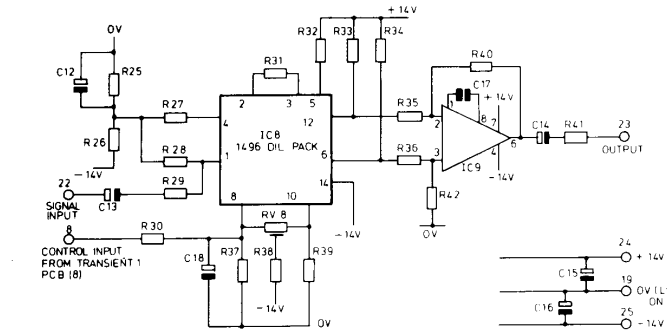

Fig. 23 Circuit Diagram of VCA Used In Envelope

16 Setting-up Envelope for 5600S

Turn all envelope front panel controls anticlockwise. Switch to linear and trigger to external and check that output of Trans board (pin 8) is at 0V. Adjust RV5 until the output of IC3 is at +5V. Turn 'delay' and 'hold level' to maximum, switch trigger to key and depress a key on the keyboard. The output should go to about +5V and stay there for about 10 seconds. Whilst the output is at +5V adjust RV4 so that the

output of IC3 is also at +5V. Recheck the 0V level and readjust if required. Repeat the procedure until both levels are correct.

Switch to exponential and check that the output of IC3 never goes negative during an envelope cycle. Turn all the controls fully anticlockwise except 'hold level' which should be turned fully clockwise. Patch a signal to the input of the envelope and patch H12/V30. Now adjust RV8 on the VCA pcb on the envelope bracket for minimum output.

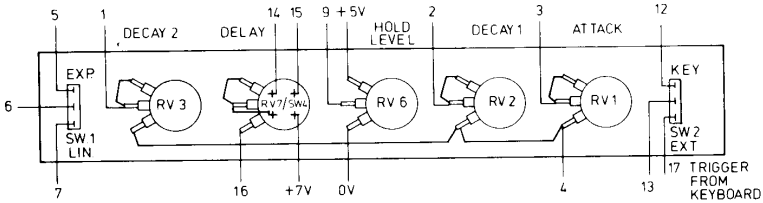

Fig. 24 Front Panel Wiring for Envelope

10 Setting-up Envelope for 3800

Turn all envelope front panel controls anticlockwise, but do not switch delay to 'key'. Switch to linear and switch envelope on the 'triggers' switches to 'external input.' Check that output of trans board (pin 8) is at 0V. Adjust RV5 until the output of IC3 is at 0V. Turn 'delay' and 'hold level' to maximum, switch envelope on 'triggers'

switches to 'keyboard' and depress a key on the keyboard. The output should go to about +5V and stay there for about 10 seconds. Whilst the output is at +5V adjust RV4 so that the output of IC3 is also at +5V. Recheck the 0V level and readjust if required. Repeat the procedure until both levels are correct.

Switch to exponential and check that the

output of IC3 never goes negative during an envelope cycle. Turn all the controls fully anticlockwise except 'hold level' which should be turned fully clockwise. Turn oscillator 1 to off, advance free run control, and switch to output. Check that a strong signal can be heard. Switch oscillator 1 to envelope. Adjust RV8 on the VCA pcb on the envelope bracket for minimum output.

VCA Construction

Assemble two VCA pcb's using the component overlay Fig. 25 taking care with the orientation of the polarised components. Mount the front panel components and the pcb on the bracket and interwire the components as shown in Fig. 27. Finally mount the two identical modules to the front panel.

VCA — How It Works

The voltage controlled amplifier is constructed around an MC1496 integrated circuit. This is a balanced modulator/demodulator, the internal circuitry of which is shown in Fig. 28. The MC1496 has differential outputs, i.e. two outputs in antiphase, which are not referred accurately to the 0V line. A buffer amp IC3, having differential inputs is therefore used to provide a single ended output.

The MC1496 has two sets of differential inputs, one set biased at about 0V and another set biased at approximately -3V. The input signal is injected into one of the -3V biased inputs (pin 1), whereas the control signal is fed to the other input, pin 8.

When using the circuit as a VCA, the

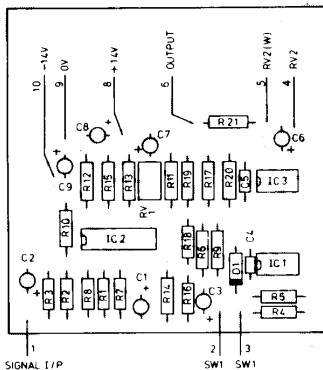

Fig. 25 Component Overlay for VCA

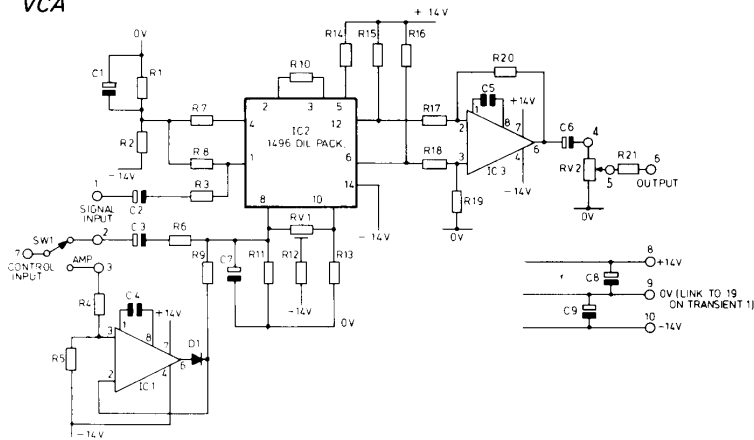

Fig. 26 Circuit Diagram of VCA

maximum possible attenuation is required when the input is 0V. However, due to tolerance variations, the 0V from other modules may be up to 20mV in error. Hence a rectifier, IC1, is used so that any voltage less than +50mV is regarded as 0V. The maximum attenuation at 0V control is adjustable by RV1.

When the module is used as a ring

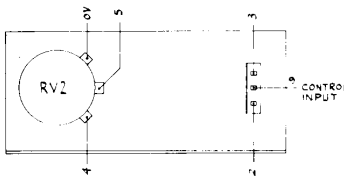

Fig. 27 Front Panel Wiring for VCA

modulator the control signal is ac coupled and the output will be the product of the two inputs.

17 Setting-up VCA for 5600S

Apply a signal to the input of each VCA in turn. Switch to amp and level to maximum. Patch H13/V11 (then H13/V12) and H16/V30 (then H17/V30) and adjust VR1 for minimum output.

11 Setting-up VCA for 3800

Switch oscillator 1 to VC Amp. Switch VC Amp control input to transient and the function switch to VCA and switch to output. Adjust slope 2 to minimum and final level fully anticlockwise on transient and adjust VR1 for minimum output.

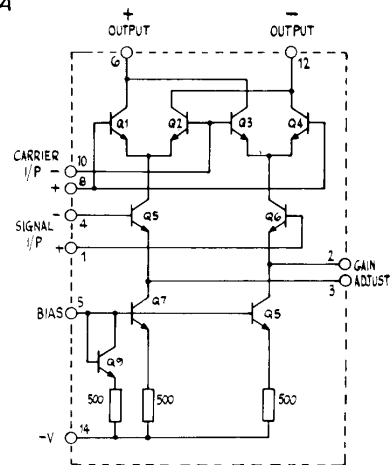

Fig. 28 Internal Circuit of MC1496

Parts List for VCA

(2 required for 5600S; 1 required for 3800)

| | |
|---------------------|-----------------------|
| R1 | Min Res 8k2 |
| R2,15,16 | Min Res 22k |
| R3 | Min Res 4k7 |
| R4,7,8,10 | Min Res 12k |
| R5 | Min Res 3M3 |
| R6 | Min Res 10k |
| R9 | Min Res 39k |
| R11,13 | Min Res 330Ω |
| R12 | Min Res 470k |
| R14,17,18,19, 20 | Min Res 100k |
| R21 | Min Res 3k3 |
| RV1 | Vert S-Min Preset 10k |

| | |
|-----------------------|------------------|
| RV2 for 5600S only | Pot Log 10k |
| C1 | Tant 33 μF 10V |
| C2,3,6 | Tant 4.7 μF 35V |
| C4,5 | Ceramic 33pF |
| C7 | Tant 0.47 μF 35V |
| C8,9 | Tant 10 μF 25V |
| IC1,3 | LM301A |
| IC2 | MC1496 |
| D1 | 1N4148 |
| SW1 | Sub-Min Toggle A |

Also required
1 VCA PCB

1 DIL Socket 14-pin
2 DIL Socket 8-pin
9 Veropin 2141
1 Wafercon Socket 8-way
8 Wafercon Terminals
2 Bolt 6BA 1/4in.
2 Nut 6BA
2 Shake 6BA

Also required for 5600S only

1 15mm Collet Knob Black
1 15mm Collet Nut Cover
1 15mm Collet Cap Blue
1 VCA Mtg Bkt

Also required for 3800 only

1 3800 VCA Bkt

Transient A and B Construction

The only difference between transient A and B is that transient A is constructed with a retrigger pcb and transient B has a retrigger pushbutton on the front panel. Assemble two transient 2 pcb's as shown in Fig. 29 and one transient retrigger pcb as shown in Fig. 33. Mount one transient 2 pcb and one retrigger pcb on one bracket and mount the front panel controls and interwire them as shown in Fig. 31. This module is transient A. Transient B simply uses one transient 2 pcb which should be fixed to the bracket along with the front panel controls and wired as shown in Fig. 32. Finally mount both modules to the front panel with transient A immediately below envelope and transient B below that.

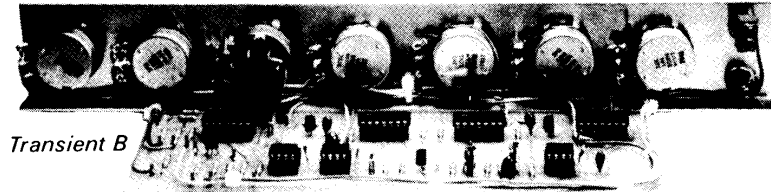
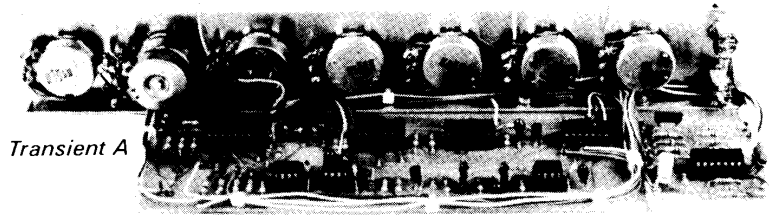

Transient 2 — How It Works

This pcb consists of two main sections.
(1) The analogue wave shaping circuitry.
(2) The digital control circuitry.

The analogue section is almost identical to the 'transient' part of the envelope and reference should be made to that. The main exception is the omission of the reset-transistor across the integrator IC. Additionally the three inputs to the comparator are all adjustable, the 'attack' potentiometer has been deleted and the 'attack time' is thus always at its maximum rate.

The digital section, however, is different and works as follows. When a trigger pulse is presented to gate IC5/4 it turns on for about 3 milliseconds. This discharges C7 via Q4. The resulting low level at the input of IC6/2 gives a 'high' output at (A) (IC6/4) and LED 1 lights. Whilst (A) is high, C4 will remain discharged.

A high output at (A) will select the maximum slope rate and the 'start level' potentiometer RV7. The output will go rapidly (within 5 milliseconds) to the level set by RV7. After the initial 3 millisecond period, C7 begins to charge at a rate selected by 'delay 1' control, RV6. When C7 charges to approximately 0V the output at (A) will go low allowing output (B) to go high selecting 'slope 1' and the 'hold level' as set by RV8. Also LED 1 is extinguished and LED 2 lights. The output will now charge towards this new level at the rate selected by 'slope 1'. At the same time C4 is also released and begins to charge. When about half charged (around 0V) the output (B) will go low and output (C) high. Thus 'slope 2' is selected and the 'final level' set by RV9. Also LED 2 is extinguished and LED 3 lights. The output cycle is now complete and the final level will be maintained until the unit is retriggered.

Note that the slopes can be in either direction depending only on the settings of the level potentiometers. Below are examples of output waveforms available.

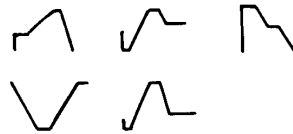

If the 'hold delay' pot, RV5, is switched off, the 'key hold' time replaces the hold delay, and, if the 'key hold' time is less than 'delay 1', then at the completion of 'delay 1', 'slope 2', and 'final level' will be selected — thus eliminating 'slope 1' and 'hold level'.

Transient Retrigger — How It Works

C3, D5, D6, R6 and R7 are used with the push-button on transient B to provide a manual trigger pulse. The rest of the board is associated with transient A and works as

follows. The normal trigger pulse from the keyboard or external input goes through D4. If it is desired to restart the transient cycle as soon as it ends then opening SW3 removes -7V from IC1d input. When the transient enters 'slope 2' and RV1 on transient A is selected, C1 starts to charge through the second gang of RV1. At the end of 'slope 2' period the voltage at the input to IC1d crosses the threshold voltage, the output goes negative and the output of IC1c goes positive. The change is speeded up by R3 which gives a positive feedback. A positive pulse appears at IC1a input 1 and IC1b inverts the pulse and further amplifies it and applies the positive pulse via D3 to the trigger input of transient A.

4 Setting-up Transient A and B for 5600S

Connect a voltmeter between the output of Transient A (e.g. the lead of R20 closest

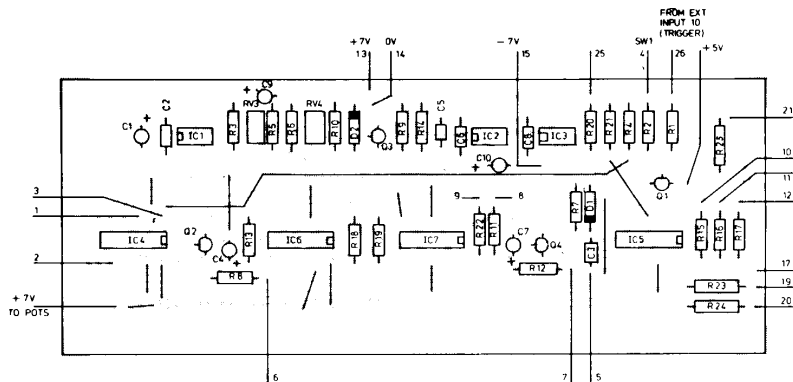

Fig. 29 Component Overlay for Transient 'A/B'

3800 & 5600S Synthesiser

The setting-up instructions for the Transient A & B in the 5600S and the Transient in the 3800 are incorrect. Setting-up should be carried out as follows. On the Transient pcb turn VR3 and VR4 fully clockwise. Turn the 'Final level' control to +10 and connect a 'scope to pin 25. Adjust VR4 until the maximum voltage is attained. Now turn VR3 fully anticlockwise and then turn it slowly clockwise until the maximum voltage is attained. If oscillation occurs turn VR4 slightly further anticlockwise and readjust VR3. In 5600S only, repeat For Transient B.

On the Transient, R20 should be removed and replaced by a wire strap. In the VCF, R11 should be a 390k.

In Fig. 69 there is a wire from FPC12 shown connected to OV. There should not be anything connected to this point. Also FPC2 has a wire shown connected to Keyboard Controller pin 23. This wire should, however, be connected to Interface pin 15.

On the Interface pcb connect a ceramic 10pF across R1 and another across R4.

In the 3800 only on the 'sample and noise' board link pins 13 and 17.

to the edge of the pcb) and 0V. Turn slope 2 to maximum and final level to -10 and adjust RV4 for 0V. Turn final level to +10 and adjust RV3 for +5V. Repeat with Transient B.

5 Setting-up Retrigger for 5600S

On Transient A, switch to 'key' and 'retrigger'. With no keys pressed and all slopes and delays at 3, check that the LED's light in rotation continuously. Now hold a key pressed and check that the rotation is arrested and LED 3 is lit permanently. Release the key and there should be no change. Quickly tap any key and the rotating sequence should restart.

8 Setting-up Transient for 3800

Connect a voltmeter between the output of the transient (e.g. the lead of R20 closest to the edge of the pcb) and 0V. Turn slope 2 to maximum and final level to -10 and adjust RV4 for 0V. Turn final level to +10 and adjust RV3 for +5V.

9 Setting-up Retrigger for 3800

Switch transient on 'triggers' switches to 'repeat'. With no keys pressed and all slopes and delays at 3, check that the LED's light in rotation continuously. Now hold a key pressed and check that the rotation is arrested and LED 3 is lit permanently. Release the key and there should be no change. Quickly tap any key and the rotating sequence should restart.

Parts List Transient A and B

(1 of each required for 5600S; 1 of 'A' only required for 3800)

| | |
|--------------------|--------------|
| R1, 19, 21, 22 | Min Res 100k |
| R2, 13, 18 | Min Res 10k |
| R3 | Min Res 15k |
| R4 | Min Res 680Ω |
| R5 | Min Res 470Ω |
| R6 | Min Res 8k2 |
| R7, 9, 11 | Min Res 1M |
| R8, 12, 15, 16, 17 | Min Res 1k2 |
| R10 | Min Res 1k8 |
| R14 | Min Res 39k |
| R20, 23, 24, 25 | Min Res 3k3 |

| | |
|--------|---------------------|
| C1 | Tant 4.7 μF 35V |
| C2, 6 | Ceramic 33pF |
| C3, 5 | Carbonate 0.0033 μF |
| C4, 7 | Tant 2.2 μF 35V |
| C8 | Ceramic 10pF |
| C9, 10 | Tant 10 μF 25V |

| | |
|------------|---------|
| Q1 | MPS3638 |
| Q2, 3, 4 | PN3643 |
| IC1, 2, 3 | LM301A |
| IC4, 5 | 4016BE |
| IC6, 7 | 4011BE |
| D1, 2 | 1N4148 |
| LED1, 2, 3 | LED Red |

RV1 a, b for
Trans A only Dual Pot Log 2M2

RV1 a for Trans
B (5600S)

| | |
|-----------|-----------------------|
| only | Pot Log 2M2 |
| RV2, 6 | Pot Log 2M2 |
| RV3, 4 | Vert S-Min Preset 22k |
| RV5 | Sw Pot Log 2M2 |
| RV7, 8, 9 | Pot Lin 22k |

SW1 for 5600S
only Sub-Min Toggle A

SW3 for 5600S
Trans A only Sub-Min Toggle A

SW4 for 5600S
Trans B only Push Sw

28

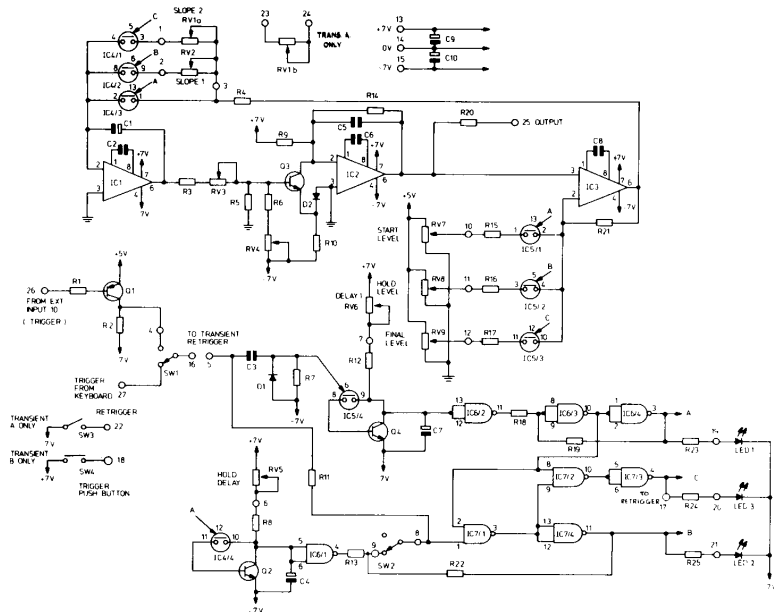

Fig. 30 Circuit Diagram of Transient 'A/B'

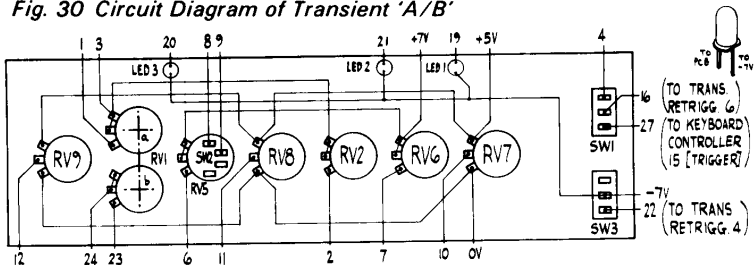

Fig. 31 Front Panel Wiring for Transient 'A'

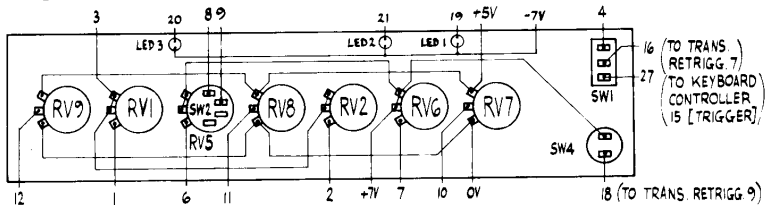

Fig. 32 Front Panel Wiring for Transient 'B'

Also required

- 1 Synth Trans 2 PCB
- 1 Trans 2 Mtg Bkt
- 4 DIL Socket 14-pin
- 3 DIL Socket 8-pin
- 1 Wafercon Skt 8-way
- 8 Wafercon Terminals
- 23 Veropin 2141
- 7 15mm Collet Knob Black
- 7 15mm Collet Nut Cover
- 2 Bolt 6BA 1/4in.
- 2 Nut 6BA
- 2 Shake 6BA
- 7 15mm Collet Cap Blue (for Trans A in 5600S only)
- 7 15mm Collet Cap Red (for Trans B in 5600S only)
- 7 15mm Collet Cap Yellow (for 3800 only)

Parts List for Transient Retrigger (1 required for 5600S; 1 required for 3800)

| | |
|----|-------------|
| R1 | Min Res 15k |
| R2 | Min Res 4M7 |
| R3 | Min Res 10M |

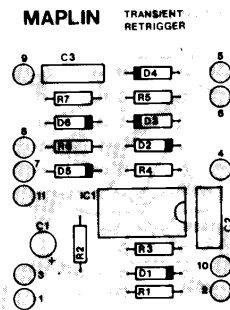

Fig. 33 Component Overlay for Transient Retrigger

- R4 Min Res 220k
- R5,6,7 Min Res 100k
- C1 PC Elect 2.2 μ F 63V
- C2 Polyester 0.1 μ F
- C3 Polyester 0.01 μ F

- D1 to 6 1N4148
- IC1 4011BE

Also required

- 1 Trans Repeat PCB
- 1 DIL Socket 14-pin
- 11 Veropin 2141
- 2 Bolt 6BA 1/4in.
- 2 Nut 6BA
- 2 Shake 6BA

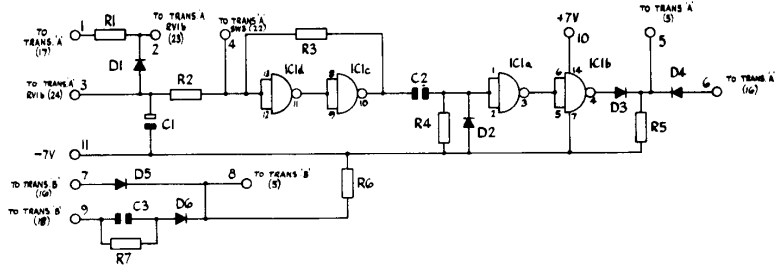

Fig. 34 Circuit Diagram of Transient Retrigger

Reverb and Phase Construction

Assemble the reverb and phase pcb using the component overlay Fig. 35. Fix the pcb to the base of the cabinet in the position shown in the internal layout photograph. Fix the spring line to the cabinet using rubber grommets. Wire the spring line to the pcb as shown in Fig. 35. Heatsinks should be clipped on to Q1 and Q2.

Reverb and Phase — How It Works

The input signal is buffered by IC1d and then split into three paths. One goes to the phasing circuitry via a low-pass filter formed around IC1a and IC1b. This filter gives a 24dB per octave cut above 10kHz to prevent high frequencies in the signal beating with the clock frequency in the bucket-brigade delay lines. The second path goes to the spring line drive circuits formed by IC2, Q1 and Q2. The push-pull transistor pair is provided to give a high current drive to the spring line which virtually eliminates mechanical noise due to the synthesiser being knocked in use. The third path goes directly to the output so that the phased or reverberated signals may be mixed with it.

The amount of phased or reverberated signal compared to straight through signal in the output is controlled by the reverb/phase level control. This control sets the amount by which Q3 attenuates the straight through signal and also after inversion by IC1c, sets the amount by which Q4 attenuates the phased or reverberated signal such that as Q3 increases the attenuation of one signal, Q4 decreases the attenuation of the other signal.

The output from the low-pass filter is fed to IC4 whose output is fed both directly to IC3a and via IC5 to IC3a. IC4 and IC5 are 512-bit bucket brigade delay lines whose delays are set by the clock frequency which is adjustable between 25kHz and greater than 500kHz.

The clock frequency is controlled either by the phase angle control or 0 to +5V level from the patchboard. IC3c buffers the control voltage and sets its reference at OV. The control voltage is linear but requires a different law to make the phasing effect linear. This is achieved by slowing the initial rate of change by clamping the voltage at the input of IC3d by D3 until the voltage exceeds the potential set by R50 and R51.

This voltage controls a voltage controlled oscillator IC6 whose frequency is set by C20 and VR2 which allows the minimum attainable frequency to be set. The output of the VCO goes to IC7 which produces two out of phase clock lines to drive IC4 and IC5.

Depending on the state of IC8 which is

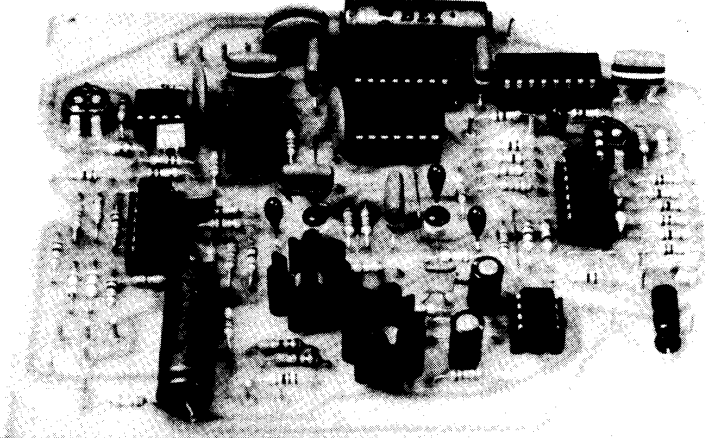

Reverb and Phase

controlled by the switch on the phase angle control the reverberated or phased signal is fed to IC3a which amplifies the signal. It also incorporates a low-pass filter to reduce the level of any clock frequency present in the phased signal. IC3b mixes together and slightly amplifies the total output signal to give the correct levels at the output.

give -5.5V. Set the phase angle control to fully anticlockwise, but not switched to reverb. Connect a frequency counter to TP1 and adjust VR2 for approximately 25kHz.

21 Setting-up Reverb and Phase

Connect a voltmeter between TP2 on the reverb/phase pcb and OV and adjust VR1 to

Parts List for Reverb and Phase (1 required for 5600S only)

- R1,2,12,17,24, 26,33,36,46, 47,53 Min Res 100k
- R3,4,6,7,8,9, 10,11,22,23, 51 Min Res 10k
- R5,43,44,56 Min Res 220k

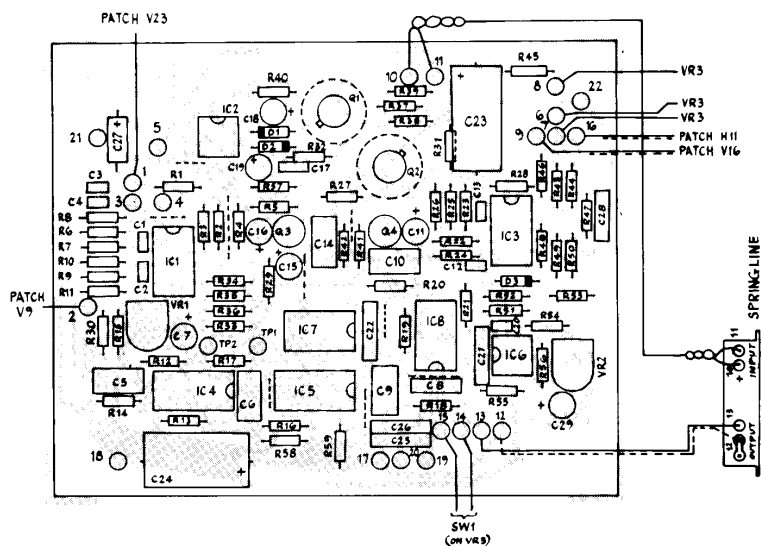

Fig. 35 Component Overlay for Reverb and Phase

- R13,55 Min Res 1k
- R14 Min Res 6k8
- R15,25 Min Res 2k7
- R16 Min Res 470k
- R18,28 Min Res 330k
- R19 Min Res 1M
- R20,27,29,32,58,59 Min Res 47k
- R21,30,35,45 Min Res 22k
- R31 Min Res 12Ω
- R34 Min Res 5k6
- R37,38 Min Res 15Ω
- R39 Min Res 10Ω
- R40,57 Min Res 15k
- R41 Min Res 1k5
- R42 Min Res 1k2
- R48 Min Res 82k
- R49 Min Res 390k
- R50 Min Res 39k
- R52 Min Res 560k
- R54 Min Res 3k9
- VR1 Hor S-Min Preset 4k7
- VR2 Hor S-Min Preset 22k
- VR3 Sw Pot Lin 25k
- VR4 Sw Pot Lin 10k
- C1 Ceramic 470pF
- C2 Ceramic 1000pF
- C3 Ceramic 10,000pF
- C4 Ceramic 3300pF
- C5,6,8,9,10,14 Polyester 0.1 μ F
- C7,11,15,16 Tant 10 μ F 16V
- C12,17 Ceramic 330pF
- C13 Ceramic 10pF
- C18,19 PC Elect 10 μ F 35V
- C20 Ceramic 100pF
- C21,22,25,26 Disc 0.1 μ F
- C23,24 Axial 470 μ F 16V
- C27 Axial 10 μ F 25V
- C28 Polyester 0.022 μ F
- C29 Tant 4.7 μ F 35V
- D1,2,3 1N4148
- Q1 BC441
- Q2 BC461
- Q3,4 2N3819
- IC1,3 4136
- IC2 741C 8-pin
- IC4,5 TDA1022
- IC6 NE566
- IC7 4013BE
- IC8 4416BE

Also required

- 1 Synth Reverb and Phase PCB
- 2 Heatsink Clip-On
- 1 Wafercon Socket 8-way
- 8 Wafercon Terminals
- 2 DIL Socket 16-pin
- 4 DIL Socket 14-pin
- 2 DIL Socket 8-pin
- 23 Veropin 2141
- 1 Short Spring-Line
- 2 Grommet Small
- 4 6BA Spacer 1/8in.
- 4 Self-Tapper No. 4 1/2in.
- 2 Self-Tapper No. 6 1/2in.
- 2 15mm Collet Knob Black
- 2 15mm Collet Nut Cover
- 1 15mm Collet Cap Blue
- 1 15mm Collet Cap Grey

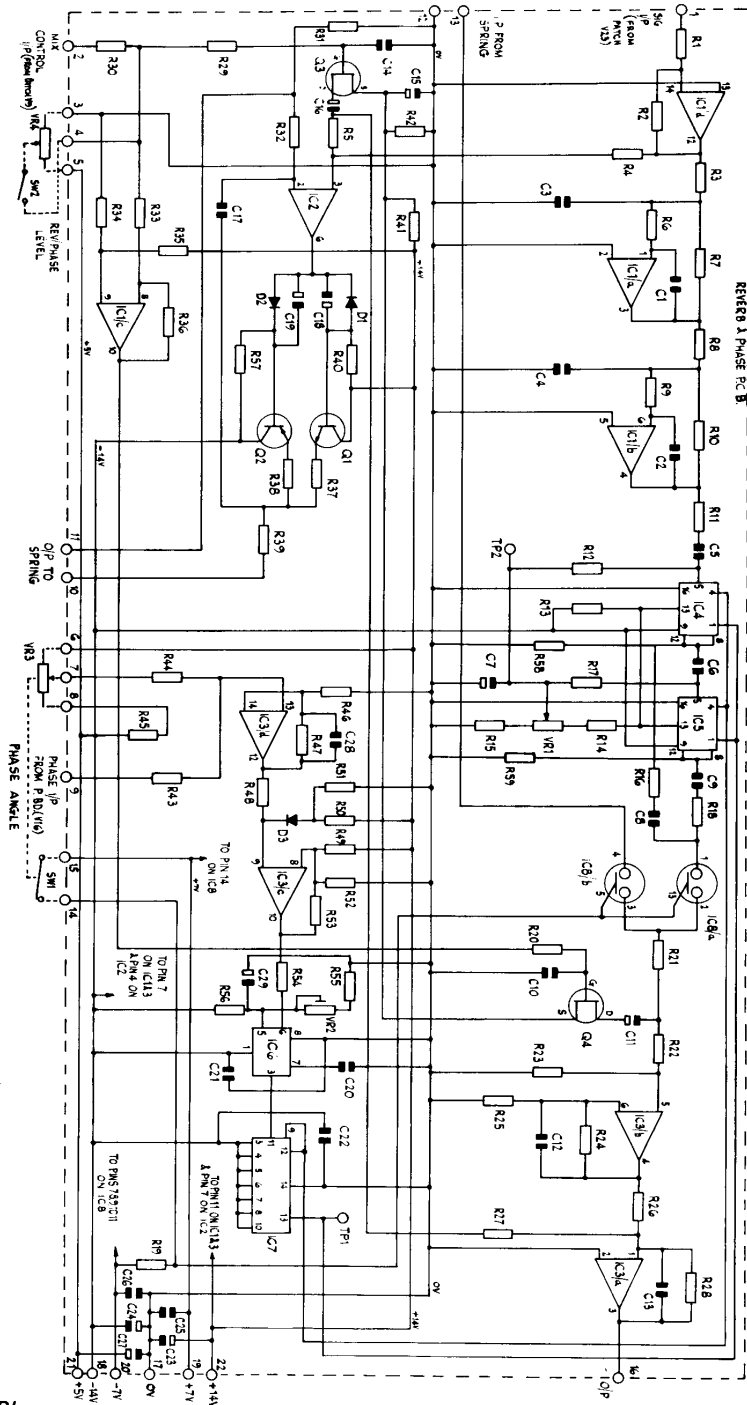
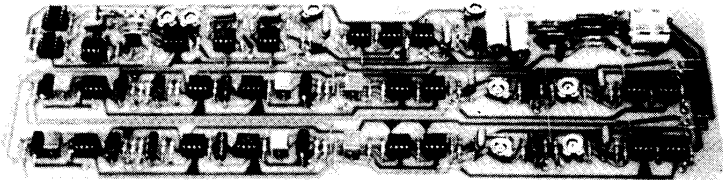

Fig. 36 Circuit Diagram of Reverb and Phase

Voltage Controlled Panning and Ancillaries (VC Pan & Anc.) Construction

Remove the 4 screws from the base and remove the base plate of the remote foot control. A resistor is soldered between one tag on the pot and the pot body. It is necessary to permanently short out this resistor. Refix the base.

Assemble the pcb as shown in Fig. 37 and when completed fix to the base of the



Voltage Controlled Panning and Ancillaries

cabinet in the position indicated in the internal layout photograph, using spacers

Continued on page 33.

Fig. 37 Component Overlay for VC Pan and Anc.

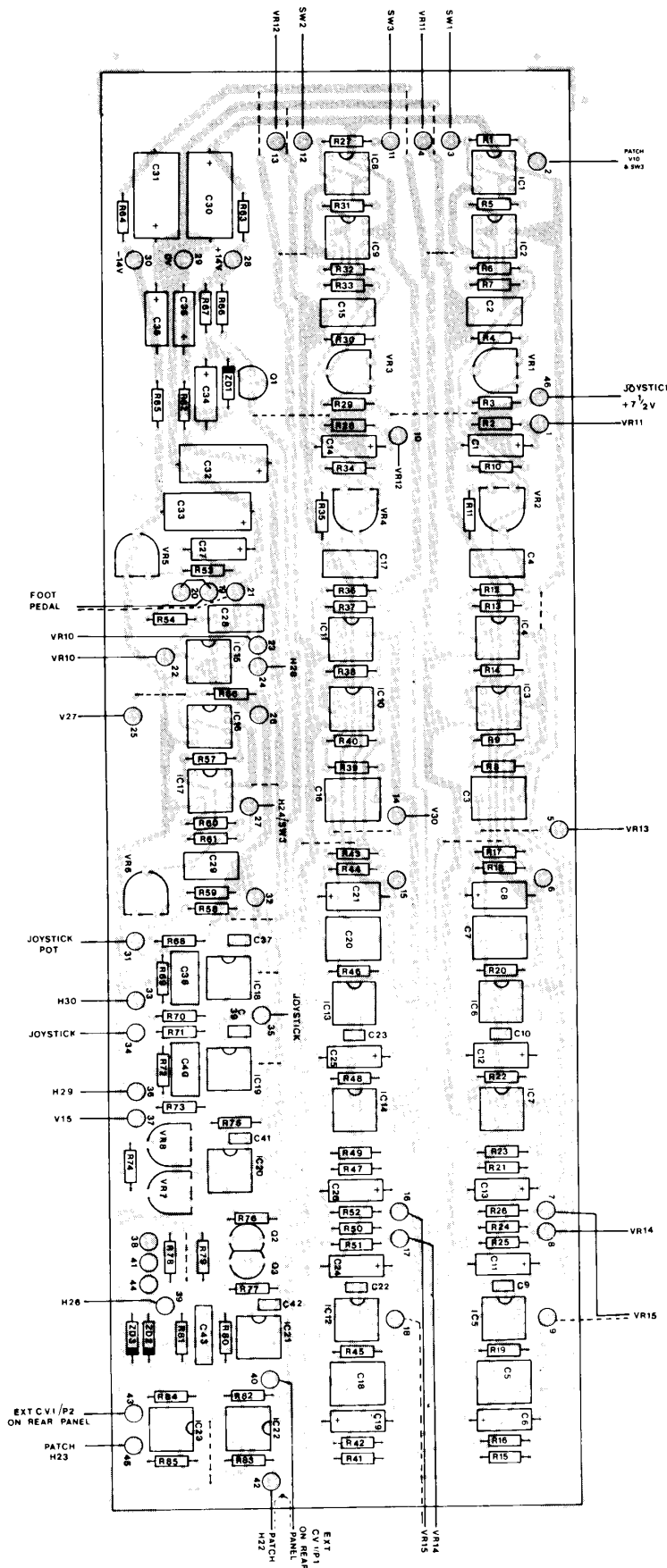

Parts List for Voltage Controlled Panning and Ancillaries

(1 required for 5600S only)

- R1,27,56 Min Res 220k
- R2,28 Min Res 4k7
- R3,4,10,11,29,30,34,35,59 Min Res 6k8
- R5,8,13,14,24,31,37,38,39,50,57,61,82,84 Min Res 100k
- R6,12,25,32,36,51,53,58,60,69,72 Min Res 10k
- R7,21,22,23,33,47,48,49,80 Min Res 47k
- R9,40 Min Res 33k
- R15,17,41,43 Min Res 8k2
- R16,18,42,44 Min Res 47Ω
- R19,20,26,45,46,52,68,71,83,85 Min Res 2k2
- R54,77,78 Min Res 22k
- R55 Not used
- R62,63,64,65 Min Res 10Ω
- R66 Min Res 220Ω
- R67 Min Res 3k9
- R70,73,76,81 Min Res 3k3
- R74 Min Res 150k
- R75 Min Res 68k
- R79 Min Res 1k2

- C1,11,12,13,14,24,25,26,34,35,36 Axial 10 μF 25V
- C2,4,15,17,28,29,38,40 Polyester 0.1 μF
- C3,5,7,16,18,20 Carbonate 1 μF
- C6,8,19,21 Axial 2.2 μF 63V
- C9,10,22,23 Ceramic 680pF
- C27 Disc 0.1 μF
- C30,31 Axial 220 μF 16V
- C32,33 Axial 100 μF 25V
- C37,39,41,42 Ceramic 33pF
- C43 Polyester 0.01 μF

- VR1,2,3,4,6 Hor S-Min Preset 10k
- VR5 Hor S-Min Preset 100k
- VR7 Hor S-Min Preset 47k
- VR8 Hor S-Min Preset 22k
- VR9 Remote Foot Control
- VR10 Pot Lin 22k
- VR11,12 Sw Pot Lin 10k
- VR13 Pot Lin 100k
- VR14,15 Dual Pot Log 10k

- SW3 Sub-Min Toggle A
- Q1 BC548
- Q2 PN3643
- Q3 MPS3638
- ZD1,2,3 BZY88C8V2

- IC1,2,3,4,7,8,9,10,11,14,15,16,17,22,23 μ A741C 8-pin DIL
- IC5,6,12,13 MC3340
- IC18,19,20,21 LM301A

Also required

- 1 VC Pan and Anc PCB
- 23 DIL Socket 8-pin
- 46 Veropin 2141
- 6 6BA Spacer 1/8in.
- 6 Self-Tapper No. 4 1/2in.
- 1 Foot Switch
- 1 Adaptor A (for Foot Switch)
- 7 15mm Collet Knob Black
- 7 15mm Collet Nut Cover
- 3 15mm Collet Cap Red
- 1 15mm Collet Cap Blue
- 2 15mm Collet Cap Green
- 1 15mm Collet Cap Grey

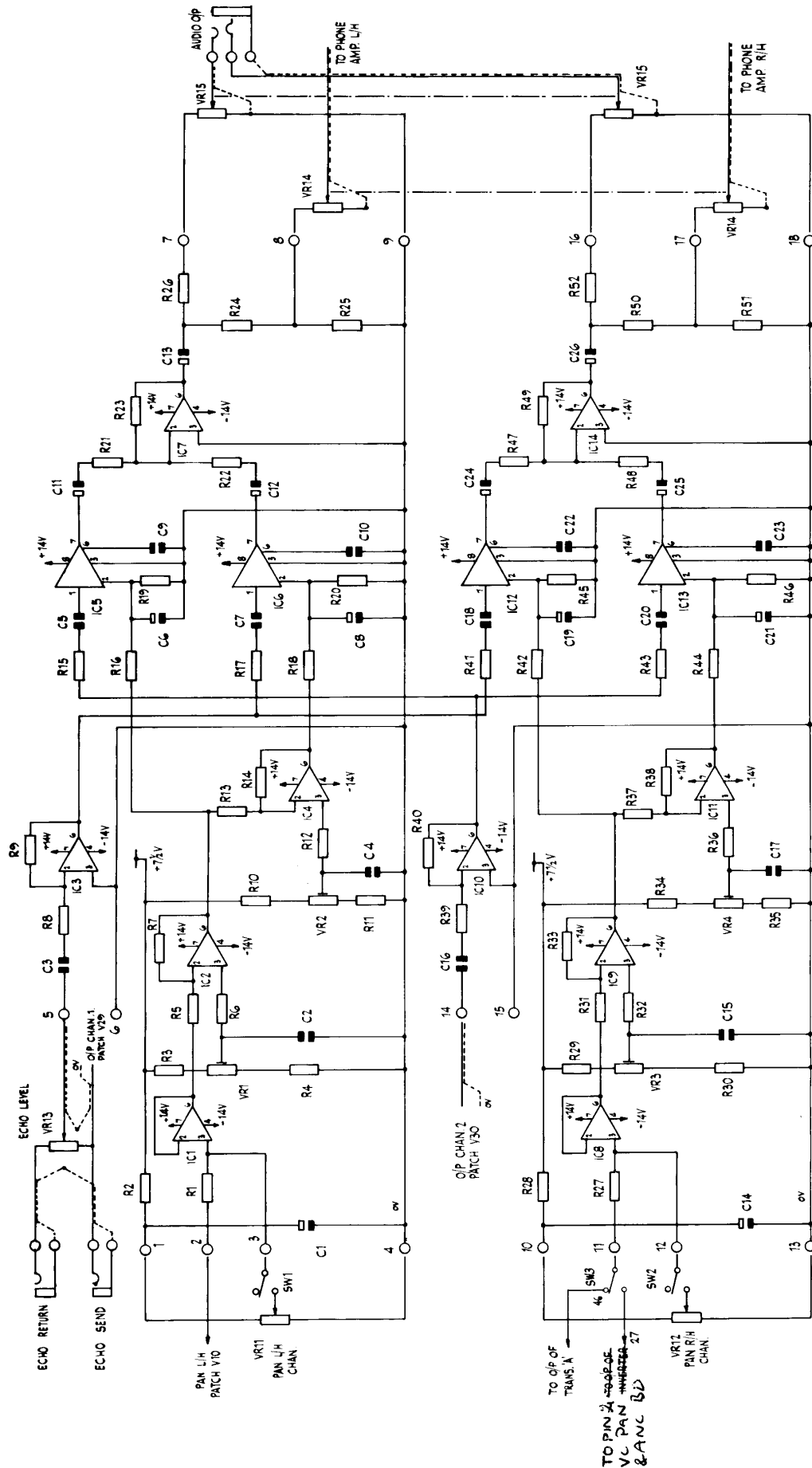

Fig. 38 Circuit Diagram of VC Panning

and self-tapping screws. Note that the flat faces of Q2 and Q3 should be smeared with Thermpath, then the two transistors pressed together and held tight by surrounding with an epoxy resin glue.

Voltage Controlled Panning — How It Works

Output channel 1 from the patchboard goes to VR13 the echo level, where echo may be added from an external echo chamber. The signal is fed via IC3 to the voltage controlled amplifiers IC6 and IC12 whose gain is controlled from pin 2, such that it decreases as the voltage becomes more positive than 0V. Output channel 2 from the patchboard is fed via IC10 to IC5 and IC13 which are also voltage controlled amplifiers. If a positive controlling voltage is applied from the patchboard to IC1 with VR11 fully anti-clockwise and therefore SW1 open, a negative going voltage appears at the output of IC2 whose level is set by VR1.

This causes IC5 to have more gain and after inversion in IC4 whose level is set by VR2, causes IC6 to have less gain. The signal appearing at the mixer amp IC7 will now come from IC5 instead of IC6 and the signal present at the patchboard channel 2 will be fed to the audio output instead of that at output channel 1. The control circuits for each output channel are identical except that the control input for channel 2 is wired via SW3 to either the output of Trans 'A' or the output of the Inverter. When VR11 is rotated clockwise, SW1 is made and the panning of the left-hand output is under the control of VR11 only.

7 Setting-up Voltage Controlled Panning

Restore all mixer controls to zero, clear patchboard, patch mixer 1 to output channel 1 and patch transient B to output channel 2 (to stop crosstalk). Patch 'key direct' to oscillator 1 and set oscillator 1 to sawtooth wave, free run to zero, tune to zero and range to 4 foot and press middle C. Turn mixer 1/oscillator 1 level and mixer 1 level fully clockwise. Turn echo level control fully anticlockwise.

Turn the pan right-hand control fully anticlockwise and connect a 'scope to pin 16 of the vc pan and anc pcb. Turn VR3 fully clockwise and measure the peak-to-peak voltage. Rotate the pan right-hand control to '0' (centre) and adjust VR3 for half the peak-to-peak voltage previously measured. Now patch mixer 1 to output channel 2 and transient B to output channel 1 and connect the 'scope to pin 7. Turn pan left-hand control fully clockwise. Turn VR1 fully clockwise and measure the peak-to-peak voltage. Rotate the pan left-hand control to '0' (centre) and adjust VR1 for half the peak-to-peak voltage previously measured.

Patch mixer 1 to output channel 1 and transient B to output channel 2. Turn pan left-hand control fully anticlockwise and adjust VR2 fully clockwise and measure the peak-to-peak voltage. Now turn the pan left-hand control to '0' (centre) and adjust VR2 for half the peak-to-peak voltage previously measured. Patch mixer 1 to output channel 2 and transient B to output channel 1 and connect the 'scope to pin 16. Turn pan right-hand control fully clockwise and adjust VR4 fully clockwise and measure the peak-to-peak voltage. Now turn the pan right-hand control to '0' (centre) and adjust VR4 for half the peak-to-peak voltage previously measured.

Remove all patch pins.

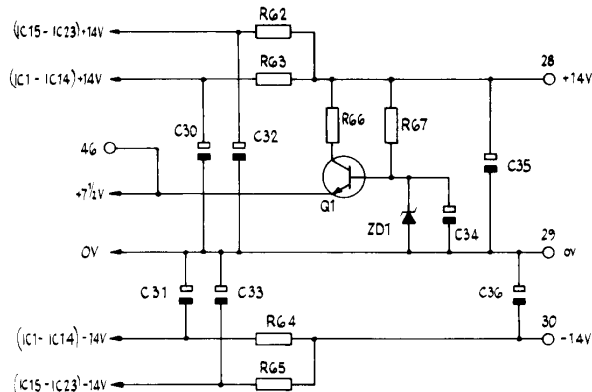

Fig. 39 Circuit Diagram of Supply Decoupling on VC Pan and Anc. Pcb

Foot Pedal — How It Works

When the foot pedal VR10 is fully depressed there is a minimum of negative feedback in IC15 and the trim pot VR5 may be set so that turning the range pot VR9 from 0 to 10 produces a voltage at the output of IC15 which will rise from 0V to +5V. Now with VR9 set fully clockwise, raising the foot pedal and thereby decreasing its resistance, increases the negative feedback in IC15 and the voltage output goes down towards 0V.

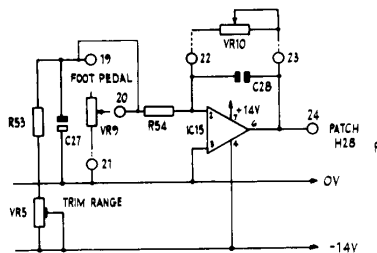

Fig. 40 Circuit Diagram of Foot Pedal Circuitry

14 Setting-up Foot Pedal

Measure with a voltmeter between H28 and 0V. Plug the foot pedal into its jack socket. With the pedal fully up the meter should read 0V. Now fully depress the foot pedal and turn the foot pedal control fully clockwise. Adjust VR5 on the VC Pan and Anc. pcb for +5V.

Inverter — How It Works

IC16 acts as a high input impedance stage driving a zero gain inverter IC17. VR6

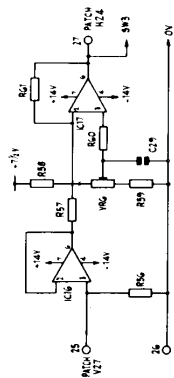

Fig. 41 Circuit Diagram of Inverter

may be adjusted so that the output voltage goes from 0V to +5V when the input voltage goes from +5V to 0V.

12 Setting-up Inverter

Remove all patch pins. Measure with a voltmeter between H24 and 0V. Adjust VR6 on VC Pan and Anc. pcb for +5V. Apply +5V to V27. Voltmeter should read 0V.

External Control Voltage Input — How It Works

These two circuits are simply voltage followers with inputs clamped by zener diodes so that the output voltage cannot go below -0.5V or above +9V.

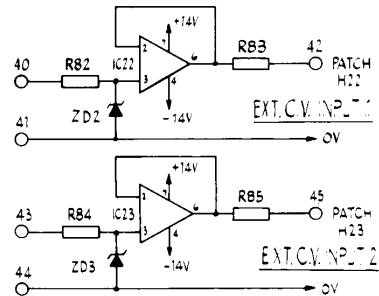

Fig. 42 Circuit Diagram of External Control Voltage Inputs

13 Setting-up External Control Voltage Inputs

Measure with a voltmeter between H22 and 0V. Apply 0V to external control voltage input number 1 socket. Voltmeter should read 0V. Apply +5V to that input and voltmeter should read +5V. Apply +14V to input and voltmeter should read around 8V. Move the voltmeter to H23 and repeat for external control voltage input 2.

Exponential Converter — How It Works

The exponential converter consists of IC20, Q2, Q3 and IC21. The input signal is inverted and attenuated by IC20; VR7 adjusts the gain and VR8 provides the required offset. The exponential relationship between the base-emitter voltage and collector current of a transistor (Q2) is used to provide the required law. Q3 provides temperature compensation as it is glued to Q2 to provide intimate thermal contact. The collector current of Q2 is converted into a proportional voltage providing an exponential relationship between input and output.

11 Setting-up Exponential Converter

Connect a wire to the +5V on the power supply and connect it to tags V1 and V2 on the patchboard. Patch H1/V29 and H1/V30. Turn mixer 1 level to 10 and mixer 1/oscillator 1 and mixer 1/oscillator 2 to 5. Turn the free run controls to '0', the waveform to sine wave and the range to 8 foot on both oscillators. Readjust the free run on oscillator 2 for minimum beats.

Remove the 5V from V2 and reconnect it to V15 (i.e. +5V is now connected to V1 and V15). Patch H26/V2. Turn VR7 on the VC Pan and Anc. pcb to the centre position and adjust VR8 until both oscillators are producing roughly the same frequency, then adjust VR7 for minimum beats. Remove the 5V from V15 only.

Connect a 0V to V15. Switch oscillator 1 to 32 foot and oscillator 2 to 1 foot. Readjust VR8 for minimum beat. Take 0V from V15 and reapply +5V. Set both oscillators to 8 foot and readjust VR7 for minimum beats. Repeat from the beginning of this paragraph until no further adjustment is required.

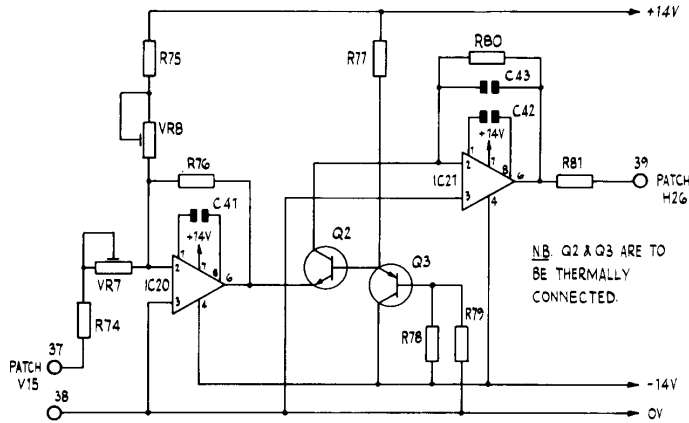

Fig. 43 Circuit Diagram of Exponential Converter

Joy Lever Construction

Assemble the joy lever pcb as shown in Fig. 45 and fix to the base using spacers and self-tapping screws in the position shown in the internal layout photograph.



Joy Lever

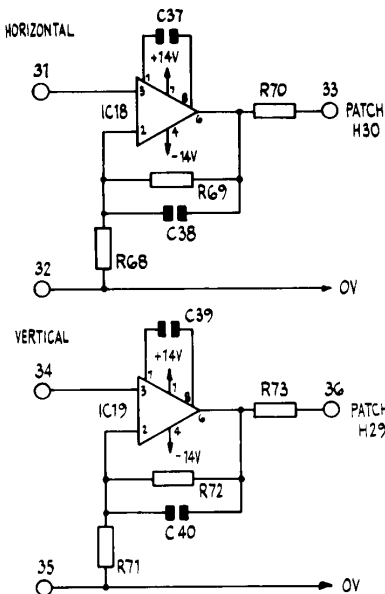

Fig. 44 Circuit Diagram of Joystick Controls

Now make the joystick.

Remove the four self-centring springs. Screw the self-tapping screws into holes 'f', 'c' and 'h' and tighten up on the spindles, then slacken off screws by turning them twice anti-clockwise. From above, centre the four zero adjusters (toothed knobs). Hold the joystick so that it appears as in Fig. 47. Slacken clamp screws 'k', 'j' and 'n'. Twist pot 'B' clockwise two or three times allowing

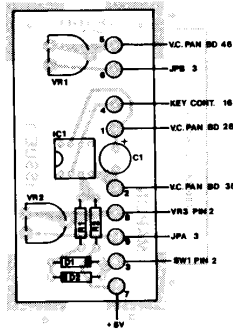

Fig. 45 Component Overlay for Joy Lever

gimbal 'P' to move freely towards pot 'A' ending up with the pot tags as shown in Fig. 47. Tighten screw 'k'. Move the stick to bring gimbal 'P' as close as possible to pot 'C' and hold gimbal in this position. Tighten screw 'f'.

With reference to Fig. 47, twist pot 'A' clockwise two or three times allowing gimbal 'Q' to move freely towards pot 'D' ending up with the pot tags as shown in Fig. 47. Tighten screw 'j'. Move the stick to bring gimbal 'Q' as close as possible to pot 'B'. Tighten screw 'c'. Holding the stick approximately vertical rotate pot 'D' two or three times clockwise ending up with the tags closest to pot 'C'. Tighten screw 'h'. Turn the pot back until its tags are as shown in Fig. 47 and tighten screw 'n'.

Fix the joystick to its mounting plate and fix the self-centring springs on pots 'B' and 'D' only. Fix SW1 and VR3 to the plate and wire the plate components to the pcb using Fig. 46 and Fig. 47.

Joy Lever — How It Works

The vertical movement of the lever causes the voltage on JPB pin 2 to go from 0V to a positive level adjustable by VR1. This is fed to IC19 on the VC Pan and Anc board which amplifies the range to give 0 to +5V. The horizontal movement is similar

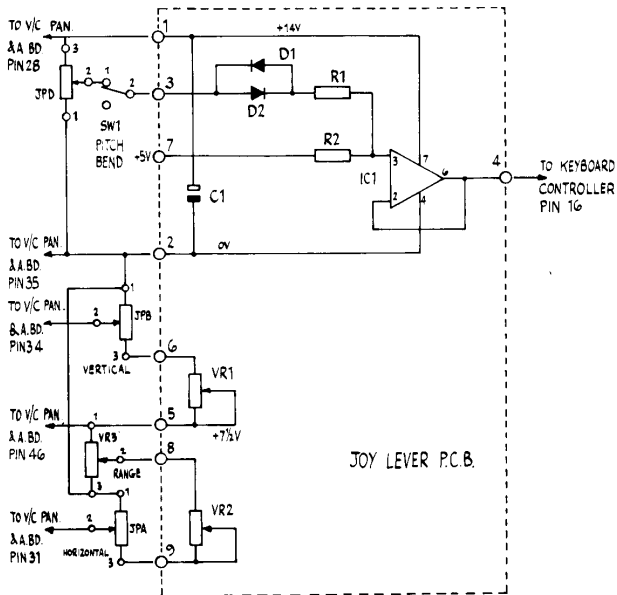

Fig. 46 Circuit Diagram of Joy Lever

except that the range may be manually adjusted by VR3.

When SW1 (pitch bend) is made, the +5V input to IC1 may be pulled higher or lower by a small amount by moving JPD above and below +5V. This causes the output voltage of IC1 to vary and this modifies the +5V on the voltage divider chain in the keyboard controller, resulting in approximately one semitone up or down change in a controlled oscillator. Diodes D1 and D2 provide about 1/2V of dead area in case the stick does not return exactly to the centre.

Parts List for Joy Lever PCB (1 required for 5600S only)

| | |
|-------|-----------------------|
| R1 | Min Res 100k |
| R2 | Min Res 47k |
| VR1,2 | Hor S-Min Preset 100k |
| VR3 | Pot Lin 10k |
| C1 | Tant 2.2 μF 35V |
| IC1 | μA741C 8-pin DIL |
| D1,2 | 1N4148 |
| SW1 | Sub-Min Toggle A |

Also required

- 1 Joy Lever PCB
- 1 Joystick Pot
- 1 Joystick Mtg Plate
- 1 DIL Socket 8-pin
- 9 Veropin 2141
- 4 6BA Spacer 1/8in.
- 4 Self-Tapper No. 4 1/2in.
- 1 15mm Collet Knob Black
- 1 15mm Collet Nut Cover
- 1 15mm Collet Cap Red

15 Setting-up Joystick

Measure with a voltmeter between H29 and 0V. Set the black knurled adjusters to their centre positions. Patch H20/V1, H1/V29 and H1/V30. Set mixer 1 level to 10 and mixer 1/oscillator 1 level to 5. Switch to 'bend', set oscillator 1 to 4 foot, tune and free run to zero and sine wave output. Press middle C. Refer to Fig. 47.

Slacken screw 'n' and rotate the body of pot 'D' to and fro without moving the joystick lever. The pitch will vary up and down, but there will be a small band over which the tone will not change. Set the pot

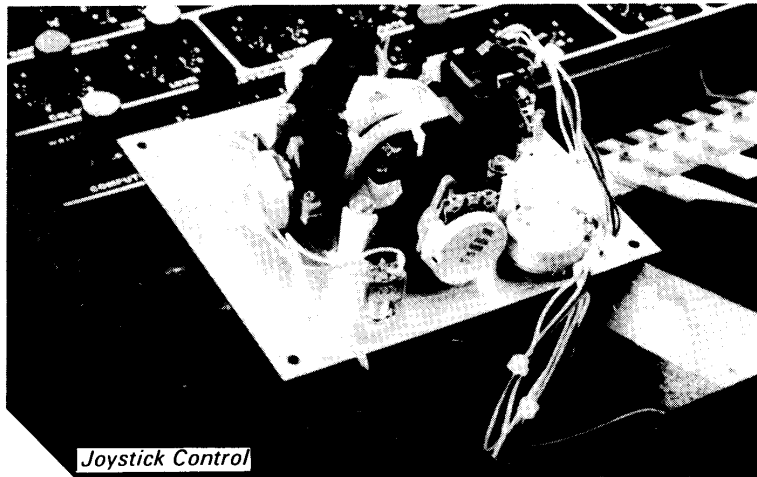

Joystick Control

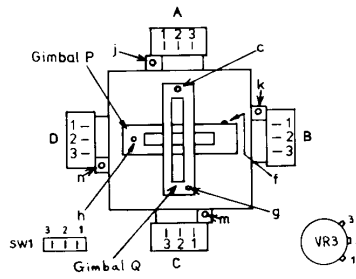

VIEW OF UNDERSIDE

Fig. 47 Joystick Control

to the centre of this band and tighten screw 'n'. With the joy lever held centrally by its own springs, switch 'bend' off and on again. The tone should not change frequency. If it does, readjust pot 'D'.

Pull the joy lever to the front and meter should read approximately 0V. If not slacken screw 'k' and rotate pot 'B' until 0V can be achieved with the joy lever pulled forward. Tighten screw 'k'. Push lever to

rear and adjust VR1 until meter reads +5V. Return to centre and adjust knurled knob for pot 'B' until meter reads 2.5V. If this cannot be achieved slacken screw 'k' again and rotate pot 'B'. Repeat above procedure until all three voltages are correct.

Measure with a voltmeter between H30 and 0V. Turn the range control to maximum and move the lever fully to the left. The meter should read about 0V. If not, slacken screw 'j' and rotate pot 'A' until 0V can be achieved with the joy lever pulled fully to the left. Tighten screw 'j'. Push lever fully to the right and adjust VR2 until the meter reads +5V. Return the lever to about the centre and adjust the knurled knob for pot 'A' until meter reads 2.5V. If this cannot be achieved slacken screw 'j' again and rotate pot 'A'. Repeat above procedure until all three voltages are correct.

Check that with the lever fully to the right, rotating the range control anti-clockwise reduces the 5V to 0V.

Joystick Control — How It Works

For description see joy lever how it works.

External Inputs Construction

The external inputs are provided so that other electronic instruments may be fed into the synthesiser in order to obtain new and different sounds. One of the two inputs has circuitry which generates trigger pulses from the external instrument's signal, thus allowing the transient generators to be triggered.

Assemble the pcb as shown in Fig. 48. Fix the front panel components to the bracket then the pcb and interwire as shown in Fig. 50. Fix the assembled module to the front panel.

External Input Specification

- Input level: 2mV to 5V rms.
- Input impedance: 50k.
- Frequency response 20Hz to 50kHz: +0 -3dB.
- Maximum gain
 - high sensitivity: 56dB
 - low sensitivity: 34dB
- Trigger level: adjustable from 0 to +5V.
- Trigger release time: approx. 20 milliseconds.

External Inputs — How It Works

The two preamplifiers for the external inputs are provided by a low-noise dual integrated circuit type LM381. A 47k

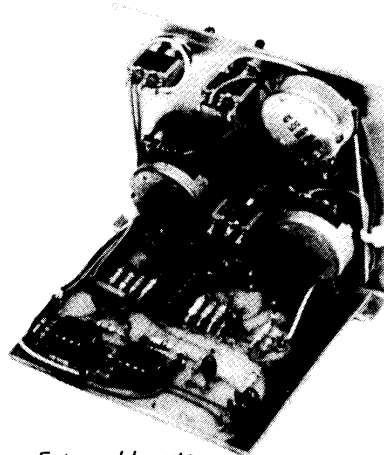

External Inputs

potentiometer at the input allows attenuation of the input and sets the input impedance.

The LM381 IC differs from the normal operational amplifier we have been using

in that it uses a single power supply of +14 volts and, in that the output has to be biased to mid-voltage (7 to 8V) by an external network — in our case R5 and R7. Gain of the amplifier is set by R7/(R1 + R3) and, since R3 may be switched in or out, two gain ranges are available. These are 56 dB and 32 dB (voltage gains of 630 and 40). These, of course, are fully variable by means of the input potentiometer.

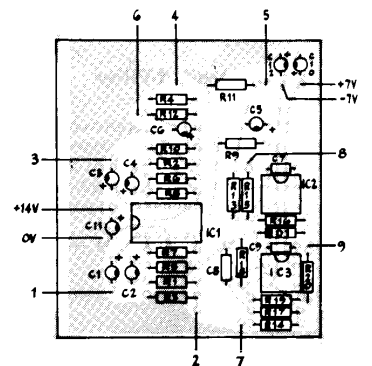

Fig. 48 Component Overlay for External Inputs