

WOODWORK

Maplin Electronic Supplies have available a high quality teak finished wooden cabinet* (see latest newsletter/price list for details) designed for use with the components they supply for this synthesiser. Constructors wishing to make their own cabinet should note that the details given below were those used in the prototype. Some of the parts now supplied differ from those used in the prototype and while the general method of construction of the cabinet shown below can be followed some of the measurements shown will need to be altered slightly.

The stops (part K) and the hinge (part M) should be assembled to the case with the aid of the front panel. Stand the unit on end and place the front panel in its normally closed position with about 2 mm clearance at the top, and 1 mm clearance at the bottom, of the panel. Mark the pivot hole position and the rear edge of the

front panel. Repeat the procedure for the other end. Drill the pivot holes 4.8 mm diameter and 10 mm deep. With the unit upright, fit the panel (using the parts M as pivots) and support it so that it is open and horizontal. Parts K can now be glued in position such that they rest on the edges of the front panel and are aligned with the pencil marks previously made. When the glue is dry parts M may be screwed into position.

The front panel may be secured in the closed position by a self-tapping screw countersunk into each side of the cabinet. The pivots and securing screws should be individually fitted on each unit to ensure proper alignment. All material, unless otherwise specified, is 13mm (1/2") chip-board.

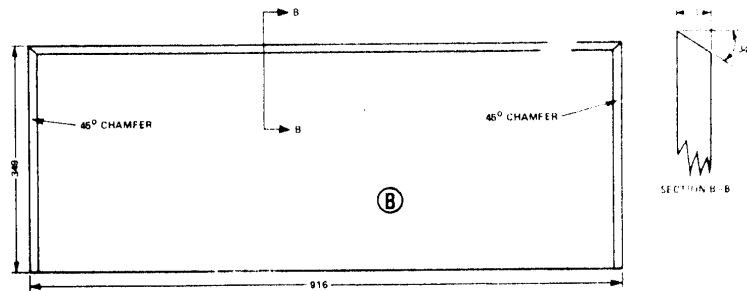
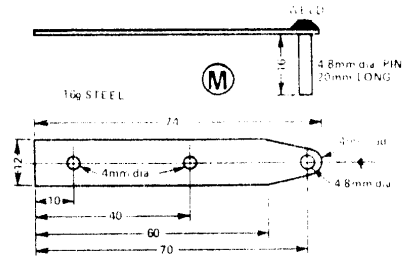
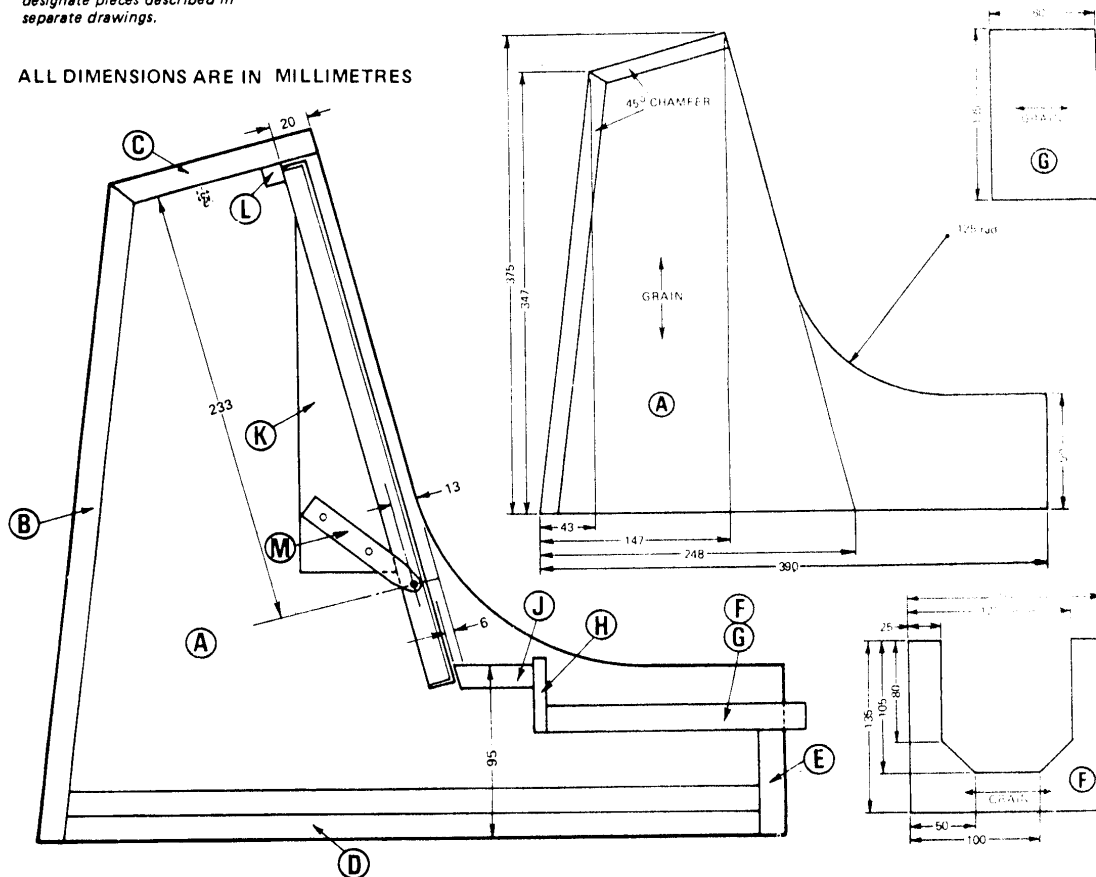
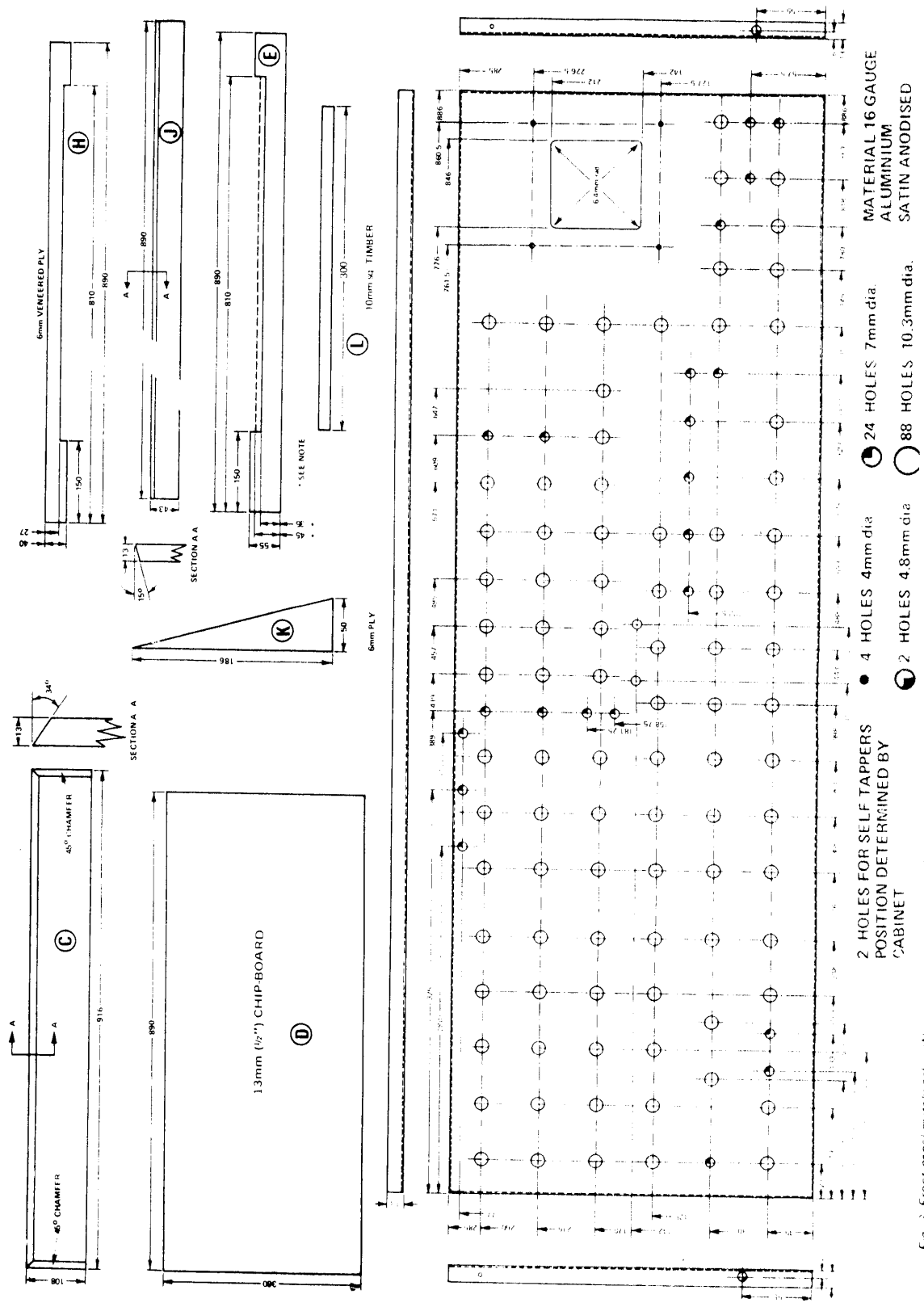

Fig.2. Cabinet assembly. Letters designate pieces described in separate drawings.

ALL DIMENSIONS ARE IN MILLIMETRES





MATERIAL 16 GAUGE ALUMINIUM SATIN ANODISED

24 HOLES 7mm dia.

88 HOLES 10.3mm dia.

2 HOLES FOR SELF TAPPERS POSITION DETERMINED BY CABINET

4 HOLES 4mm dia

Fig. 3. Front Panel Detailwork (Not shown in sample as that supplied by Maplin Ltd. (Maplin & Co. Supplies))